



NORTH-WEST UNIVERSITY<sup>®</sup>  
YUNIBESITI YA BOKONE-BOPHIRIMA  
NOORDWES-UNIVERSITEIT

POTCHEFSTROOM CAMPUS  
ENGINEERING



# **CALENDAR 2016**

FACULTY OF ENGINEERING  
POSTGRADUATE

**Potchefstroom Campus**

Address all correspondence to:

The Registrar  
North-West University  
Potchefstroom Campus  
Private Bag X6001  
Potchefstroom  
2520

Tel: (018) 299 1111/2222

Fax: (018) 299 2799

Web page: <http://www.nwu.ac.za>

PLEASE MENTION YOUR UNIVERSITY NUMBER IN ALL CORRESPONDENCE.

The General Academic Rules of the University, which all students subject to and which apply to all the qualifications offered by the University, appear in a separate publication and are available on the web page at: <http://www.nwu.ac.za/postgrad/how-to-apply>.

**Please note:** Although the information in this Calendar has been compiled with the utmost care and accuracy, the Council and the Senate of the University accept no responsibility whatsoever for errors that may occur. Before students make a final decision on their selection of modules, they must consult the class timetable. If a clash occurs in the planned selection of a student, the relevant module combination is not permitted.

## Table of Contents

<b>I.1</b>	<b>FACULTY RULES .....</b>	<b>12</b>
<b>I.1.1</b>	<b>AUTHORITY OF THE GENERAL RULES .....</b>	<b>12</b>
<b>I.1.2</b>	<b>FACULTY-SPECIFIC RULES .....</b>	<b>12</b>
I.1.2.1	Admission .....	12
I.1.2.2	Selection .....	13
I.1.2.3	Registration .....	14
I.1.2.4	Duration of registration .....	14
I.1.2.5	Amendment or cancellation of registration .....	14
I.1.2.6	Erroneous registration .....	14
I.1.2.7	Exemption from registration .....	14
I.1.2.8	Simultaneous registration at more than one institution .....	14
I.1.2.9	Simultaneous registration for more than one qualification .....	15
I.1.2.10	Re-admission after failure to register .....	15
I.1.2.11	Extension of study period .....	15
I.1.2.12	Registration for additional modules .....	15
I.1.2.13	Recognition of and exemption from modules .....	15
I.1.2.14	Research proposal and title registration for master's and doctoral degrees .....	16
I.1.2.15	Classification of dissertations and theses .....	16
I.1.2.16	Upgrade of master's degree study to doctoral study .....	16
I.1.2.17	Termination of study .....	16
I.1.2.18	Examination .....	17
I.1.2.19	Submission of dissertation or thesis for examination .....	17
<b>I.1.3</b>	<b>LANGUAGE POLICY .....</b>	<b>17</b>
<b>I.1.4</b>	<b>WARNING AGAINST PLAGIARISM .....</b>	<b>17</b>
<b>I.1.5</b>	<b>CAPACITY STIPULATION .....</b>	<b>18</b>
<b>I.1.6</b>	<b>SCHOOLS OF THE FACULTY .....</b>	<b>18</b>
<b>I.1.7</b>	<b>QUALIFICATIONS, PROGRAMMES AND CURRICULA .....</b>	<b>19</b>
<b>I.1.8</b>	<b>RULES FOR THE POSTGRADUATE DIPLOMA .....</b>	<b>21</b>
I.1.8.1	Duration (minimum and maximum duration) .....	21
I.1.8.2	Admission requirements for the qualification .....	21
I.1.8.3	Method of presentation .....	21
I.1.8.4	Postgraduate Diploma in Nuclear Science and Technology Qualification Code: 705 100 .....	21
I.1.8.5	Curriculum: I501P .....	22
<b>I.1.9</b>	<b>RULES FOR THE DEGREE MASTER OF ENGINEERING .....</b>	<b>23</b>
I.1.9.1	Duration (minimum and maximum duration) .....	23
I.1.9.2	Admission requirements for the qualification .....	23

I.1.9.3	Composition of the programme .....	23
I.1.9.4	Requirements for a dissertation.....	24
I.1.9.5	Faculty-specific requirements.....	25
I.1.9.6	Articulation possibilities .....	25
I.1.9.7	List of modules .....	25
I.1.9.8	Course modules from other MEng and/or other curricula.....	27
I.1.9.9	MEng in Chemical Engineering Qualification Code: 702 110 .....	28
I.1.9.10	MEng in Computer and Electronic Engineering Qualification Code: 702 109 .....	29
I.1.9.11	MEng in Electrical and Electronic Engineering Qualification Code: 702 108 .....	30
I.1.9.12	MEng in Mechanical Engineering Qualification Code: 702 107 .....	31
I.1.9.13	MEng in Nuclear Engineering Qualification Code: 702 104 .....	32
I.1.9.14	MEng in Development and Management Engineering Qualification Code: 702 111 .....	34
<b>I.1.10</b>	<b>RULES FOR THE DEGREE MASTER OF SCIENCE IN ENGINEERING SCIENCES .....</b>	<b>35</b>
I.1.10.1	Duration (minimum and maximum duration) .....	35
I.1.10.2	Admission requirements for the qualification .....	35
I.1.10.3	Composition of the programme .....	35
I.1.10.4	Requirements for a dissertation.....	37
I.1.10.5	Faculty-specific requirements.....	37
I.1.10.6	Articulation possibilities .....	37
I.1.10.7	List of modules .....	37
I.1.10.8	Course modules from other MSc and/or other curricula .....	39
I.1.10.9	MSc in Chemical Engineering Qualification Code: 203 152 .....	40
I.1.10.10	MSc in Computer and Electronic Engineering Qualification Code: 203 154 .....	41
I.1.10.11	MSc in Electrical and Electronic Engineering Qualification Code: 203 153 .....	42
I.1.10.12	MSc in Mechanical Engineering Qualification Code: 203 151 .....	43
I.1.10.13	MSc in Nuclear Engineering Qualification Code: 203 200 .....	44
<b>I.1.11</b>	<b>RULES FOR THE DEGREE OF PHILOSOPHIAE DOCTOR .....</b>	<b>46</b>
I.1.11.1	Duration (minimum and maximum duration) .....	46
I.1.11.2	Admission requirements for the qualification .....	46
I.1.11.3	Faculty-specific requirements.....	46

I.1.11.4	Requirements for a thesis .....	47
I.1.11.5	Outcomes .....	47
I.1.11.6	Articulation possibilities .....	47
I.1.11.7	Programme .....	48
<b>I.2</b>	<b>MODULE OUTCOMES .....</b>	<b>49</b>

## **Office Bearers**

### **Dean**

Prof LJ Grobler – PrEng, CEM, CMVP, PhD (*University of Pretoria*).

### **Directors of Schools / Research Units**

#### **Unit for Engineering Research**

Prof L van Dyk – PrEng, SAIIIE, PhD (*Stellenbosch*), MEng (*Pretoria*), MSc (*Worwick*), BEng (*Pretoria*).

#### **School of Chemical and Minerals Engineering**

Prof FB Waanders – PrEng, PrSciNat, DSc (*PU for CHE*).

#### **School of Electrical, Electronic and Computer Engineering**

Prof JA de Kock – PrEng, PhD, MEng, BEng.

#### **School of Mechanical and Nuclear Engineering**

Prof JH Wichers – PrEng, SAIMEchE, PhD, MENG, BEng.

### **Centre for Research and Continued Engineering Development (CRCED)**

#### **CRCED Pretoria**

Prof EH Mathews (Manager) – PrEng, PhD (*PU for CHE*).

### **Postgraduate Programme Managers**

#### **School of Chemical and Minerals Engineering**

Prof S Marx

#### **School of Electrical, Electronic and Computer Engineering**

Prof AJ Hoffman

#### **School of Mechanical and Nuclear Engineering**

Prof M van Eldik

### **Administrative Manager**

Ms L Viljoen

Ms D Zietsman

# Faculty Council

## Chairperson

Prof LJ Grobler (*Dean*)

## School Directors / Programme Managers and Academic personnel

### School of Chemical and Minerals Engineering

Prof FB Waanders (*Director*)

Prof M le Roux (*Undergraduate Programme Manager*)

Prof S Marx (*Postgraduate Programme Manager*)

### School of Electrical, Electronic and Computer Engineering

Prof JA de Kock (*Director*)

Prof WC Venter (*Undergraduate Programme Manager: Computer and Electronic Engineering*)

Prof R Gouws (*Undergraduate Programme Manager: Electrical and Electronic; Electromechanical Engineering*)

Prof AJ Hoffman (*Postgraduate Programme Manager*)

### School of Mechanical and Nuclear Engineering

Prof JH Wichers (*Director*)

Dr JJ Janse van Rensburg (*Undergraduate Programme Manager: Mechanical Engineering*)

Prof L van Dyk (*Undergraduate Programme Manager: Industrial Engineering*)

Prof M van Eldik (*Postgraduate Programme Manager*)

### Academic representative from the Faculty of Natural Sciences

Prof HCM Vosloo

### Teaching-Learning and Quality affairs

Prof M le Roux (*Chairman: Teaching and Learning Committee*)

Ms V Pretorius (*Senior Administrative Assistant*)

### Innovation Support Office

Mr AG Hattingh (*Project Manager*)



### **Unit for Engineering Research**

Prof L van Dyk (*Director*)

### **Centre for Research and Continued Engineering Development (Pretoria)**

Prof EH Mathews (*Manager*)

### **Recruitment, Selection, Bursaries and Student Affairs**

Ms EC Hattingh (*Manager*)

### **Undergraduate Teaching-Learning**

Mrs MCJ Potgieter (*Administrative Manager, Secretariat*)

### **Postgraduate Administration**

Ms L Viljoen (*Administrative Manager*)

### **Student Representative**

ESA-Chairperson (*Engineering Student Association*)

## **Research**

Research in the Faculty is managed in the following research subgroups.

### **Research Chairs**

#### **DTI Chair in Nuclear Engineering**

Prof CG du Toit

**E-mail:** [Jat.DuToit@nwu.ac.za](mailto:Jat.DuToit@nwu.ac.za)

#### **Coal Chair as part of SARCHI**

Prof JR Bunt

**E-mail:** [John.Bunt@nwu.ac.za](mailto:John.Bunt@nwu.ac.za)

#### **NRF Research Chair in Biofuels**

Prof S Marx

**E-mail:** [Sanette.Marx@nwu.ac.za](mailto:Sanette.Marx@nwu.ac.za)

### **Chair in Smart Grids**

Prof APJ Rens

**E-mail:** [Johan.Rens@nwu.ac.za](mailto:Johan.Rens@nwu.ac.za)

### **BBE Energy Chair for Energy Innovation**

Prof JA de Kock

**E-mail:** [Jan.deKock@nwu.ac.za](mailto:Jan.deKock@nwu.ac.za)

### **Subgroups**

Visit the website for more information on each subgroup: <http://www.nwu.ac.za/p-fe/research-groups.html>

#### **Aerodynamic Design and Aircraft Development Group**

Dr AS Jonker

**E-mail:** [Attie.Jonker@nwu.ac.za](mailto:Attie.Jonker@nwu.ac.za)

#### **Bio-Energy Research Group**

Prof S Marx

**E-mail:** [Sanette.Marx@nwu.ac.za](mailto:Sanette.Marx@nwu.ac.za)

#### **Centre for Advanced Additive Manufacturing**

Mr DB Vorster

**E-mail:** [Danie.Vorster@nwu.ac.za](mailto:Danie.Vorster@nwu.ac.za)

#### **Coal Research Group**

Prof JR Bunt

**E-mail:** [John.Bunt@nwu.ac.za](mailto:John.Bunt@nwu.ac.za)

#### **DST-HySA (Hydrogen South Africa) Infrastructure Centre of Competence**

Dr D Bessarabov

**E-mail:** [Dmitri.Bessarabov@nwu.ac.za](mailto:Dmitri.Bessarabov@nwu.ac.za)

**Energy Research Group (ERG)**

Prof R Gouws

**E-mail:** [Rupert.Gouws@nwu.ac.za](mailto:Rupert.Gouws@nwu.ac.za)

**Engineering Management**

Prof JH Wichers

**E-mail:** [Harry.Wichers@nwu.ac.za](mailto:Harry.Wichers@nwu.ac.za)

**Industrial Engineering**

Prof L van Dyk

**E-mail:** [Liezl.vanDyk@nwu.ac.za](mailto:Liezl.vanDyk@nwu.ac.za)

**Intelligent Systems**

Prof AJ Hoffman

**E-mail:** [Alwyn.Hoffman@nwu.ac.za](mailto:Alwyn.Hoffman@nwu.ac.za)

**Materials, Vibration Analysis and Manufacturing**

Prof J Markgraaff

**E-mail:** [Johan.Markgraaff@nwu.ac.za](mailto:Johan.Markgraaff@nwu.ac.za)

**McTronX**

Prof G van Schoor

**E-mail:** [George.vanSchoor@nwu.ac.za](mailto:George.vanSchoor@nwu.ac.za)

**Minerals Processing and Water Research Group**

Prof FB Waanders

**E-mail:** [Frans.Waanders@nwu.ac.za](mailto:Frans.Waanders@nwu.ac.za)

**Nuclear Engineering and Neutronics**

Dr AC Cilliers

**E-mail:** [Anthonie.Cilliers@nwu.ac.za](mailto:Anthonie.Cilliers@nwu.ac.za)

**Telenet Research Group**

Prof AS Helberg

E-mail: [Albert.Helberg@nwu.ac.za](mailto:Albert.Helberg@nwu.ac.za)

**Thermal and Dynamic System Process Optimization Group**

Prof CP Storm

E-mail: [Chris.Storm@nwu.ac.za](mailto:Chris.Storm@nwu.ac.za)

**Thermal-Fluid Systems Group**

Prof M van Eldik

E-mail: [Martin.vanEldik@nwu.ac.za](mailto:Martin.vanEldik@nwu.ac.za)

## Contact Details

**Applications and Enquiries – Postgraduate Studies**

Postgraduate Administrative Manager

Ms D Zietsman

E-mail: [EngineerPostgrad-info@nwu.ac.za](mailto:EngineerPostgrad-info@nwu.ac.za)

**Enquiries regarding research opportunities within different subgroups**

Research Administrative Manager

Mrs L Gertenbach

E-mail: [Louise.Gertenbach@nwu.ac.za](mailto:Louise.Gertenbach@nwu.ac.za)

**Postgraduate Programme Managers****School of Chemical and Minerals Engineering**

Prof S Marx

Tel: (018) 299 1995

E-mail: [Sanette.Marx@nwu.ac.za](mailto:Sanette.Marx@nwu.ac.za)

**School of Electrical, Electronic and Computer Engineering**

Prof AJ Hoffman

Tel: (018) 299 1963

E-mail: [Alwyn.Hoffman@nwu.ac.za](mailto:Alwyn.Hoffman@nwu.ac.za)

**School of Mechanical and Nuclear Engineering**

Prof M van Eldik

**Tel:** (018) 299 1324

**E-mail:** [Martin.VanEldik@nwu.ac.za](mailto:Martin.VanEldik@nwu.ac.za)

**Centre for Research and Continued Engineering Development (CRCED Pretoria)**

**Tel:** (012) 809 0412

**Fax:** (086) 231 0366

**Physical Address:**

77 Tyger Valley

Office Park

13 Pony Street

Tyger Valley

PRETORIA

**Postal Address:**

P.O. Box 112211

Silver Lakes

0054

## I.1 FACULTY RULES

### I.1.1 AUTHORITY OF THE GENERAL RULES

The Faculty Rules valid for the different qualifications, programmes and curricula of this Faculty and contained in this Faculty calendar are subject to the General Rules of the University, as determined from time to time by the Council of the University on the recommendation of the Senate. The Faculty Rules should therefore be read in conjunction with the General Rules.

The General ACADEMIC RULES can be found on the University's website at <http://www.nwu.ac.za/postgrad/how-to-apply> or, alternatively, the Academic Administration department of the University can be consulted.

Further guidelines and rules regarding postgraduate study are given in the **Manual for Postgraduate Studies**. All students are required to consult this manual in detail. A version of this manual is available on the University's web site (<http://www.nwu.ac.za/postgrad/how-to-apply>).

### I.1.2 FACULTY-SPECIFIC RULES

Additional requirements and/or faculty-specific rules with regard to different programmes are reflected at a specific programme.

#### I.1.2.1 Admission

The admission and registration requirements are set out in Academic Rules A.4.2. and A.4.3.

Prospective students apply for admission to the North-West University – forms and information available from Higher Degree Administration – Postgraduate Admissions – telephone (018) 299 4274.

Prospective students must consult the Postgraduate Prospectus to help them identify a study leader. The Prospectus provides a list of research projects available for students to participate in. The study leader will then sign a study leader acceptance form, which must accompany the application form. Students will not be allowed to register unless a study leader has been confirmed. The Prospectus is available from the Postgraduate Administrative Officer – e-mail: [EngineerPostgrad-info@nwu.ac.za](mailto:EngineerPostgrad-info@nwu.ac.za) or on the website: [www.nwu.ac.za](http://www.nwu.ac.za).

**Please note:** Applications have a consideration period of approximately four (4) weeks, after being received by the Faculty for evaluation. This turnaround time is additional to the time required by the Higher Degree Administration department to finalize the admission process.

After a student has been admitted, registration forms are issued, which must be signed by the Faculty Postgraduate Administration Officer before the student will be allowed to register. The prescribed fees must also be paid BEFORE registration.

Students must re-register every year according to the prescribed procedure on or before the date set by the University.

The process can be illustrated as follows:

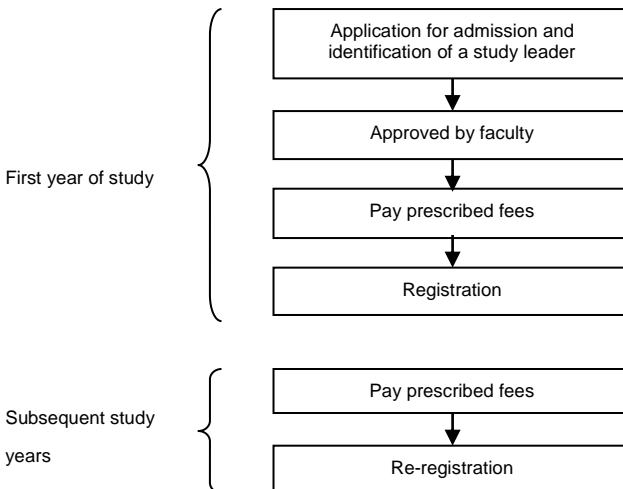

*Note: No student will be allowed to attend the lectures of a particular module unless the prescribed registration fee has been paid.*

### **Foreign qualifications**

Students holding a foreign qualification (i.e. not obtained at a South African University), are required to have the qualification evaluated by SAQA (South African Qualifications Authority) and a certificate of evaluation must be submitted with the application form. For more information, contact SAQA at [www.saqa.org.za](http://www.saqa.org.za).

For further information regarding foreign students, please visit the University's International Office on the following website: <http://www.nwu.ac.za/nwu/students/int.html>.

### **Recognition of Prior Learning (RPL)**

The Faculty's policy with regard to Recognition of Prior Learning applies. Students must consult the NWU RPL Policy on the website: [http://www.nwu.ac.za/content/policy\\_rules](http://www.nwu.ac.za/content/policy_rules) and the Faculty RPL Workflow and Standard for RPL Portfolio for the correct processes and procedures to be followed. The Workflow and Standard for RPL Portfolio is available from the Postgraduate Administrative Officer – e-mail: [EngineerPostgrad-info@nwu.ac.za](mailto:EngineerPostgrad-info@nwu.ac.za).

#### **I.1.2.2**

### **Selection**

The Faculty reserves the right to select students before admission to specific programmes and not to admit applicants to the relevant qualification programmes if they do not meet the selection criteria, even where such applicants do meet the minimum admission requirements. Where, in such a case, a student number is allocated to an applicant, it is done solely for administrative purposes, and does not constitute or create right to admission.

Selection processes are approved by faculty structures and are revised annually.

#### **I.1.2.3 Registration**

A student who has been admitted to the University registers for a specific qualification programme per annum for the duration of the study at the time determined in the annual calendar for that purpose, by paying the prescribed registration fee, completing a registration form either on paper or electronically and acquiring the required approval from the study leader concerned. Thereafter the student must have the registration form signed by the Faculty Postgraduate Administration Officer before submitting the form to the office concerned, upon which proof of registration is issued to the student. The aforementioned is also applicable to the re-registration of existing students. If a provisional postgraduate student fails to register during the determined registration cycle of the specific academic year, he/she must re-apply for admission to the University (I.1.2.10).

An existing postgraduate student who fails to re-register for any academic year, must apply for re-admission and continuation. Such student will be responsible for paying outstanding tuition fees of preceding year(s) as well (I.1.2.10).

#### **I.1.2.4 Duration of registration**

A postgraduate student who is admitted to the University and officially registered remains a student of the University for as long as the registration is valid, or until such time the registration is cancelled by the student or by the faculty due to inadequate progress.

#### **I.1.2.5 Amendment or cancellation of registration**

A postgraduate student's registration may only be amended or cancelled on application in the prescribed manner. The Faculty may cancel a student's registration for a particular module if such registration was done contrary to Faculty rules.

A student whose registration is cancelled and who received bursaries from the University are liable to make arrangements for reimbursement.

#### **I.1.2.6 Erroneous registration**

The University reserves the right to cancel any erroneous registration and to withdraw any qualification that was awarded erroneously after the conclusion of a disciplinary process or the completion of a thorough administrative enquiry.

#### **I.1.2.7 Exemption from registration**

A postgraduate student who still needs to write a paper or make improvements to an examined dissertation or thesis and who can still attain the qualification at the autumn graduation ceremony, does not register for a new year, provided that the examination is successfully completed by the end of January of the new year or the dissertation or thesis is satisfactorily improved by the end of January of that new year.

#### **I.1.2.8 Simultaneous registration at more than one institution**

A postgraduate student may not be registered simultaneously at the University and at another higher education institution without written permission granted by the Dean and with the concurrence of the other institution.



### **I.1.2.9 Simultaneous registration for more than one qualification**

A postgraduate student may not be registered simultaneously for more than one qualification at the University without prior written permission granted by the Dean or Deans concerned.

### **I.1.2.10 Re-admission after failure to register**

Interruption of master's and doctoral studies is not allowed. A student's studies will be terminated by the Postgraduate Faculty Administration if he/she fails to re-register for an academic year.

A student whose registration is terminated and who received bursaries from the University are liable to make arrangements for reimbursement.

Where a postgraduate student's studies were terminated because of failure to re-register, such a student must apply anew for admission by completing the relevant forms. Refer to I.1.2.1.

A student is only allowed to apply twice towards the same qualification. Upon re-application, the student must identify a new study leader and research topic. A student intending to continue previous unfinished studies must re-apply for admission by completing the relevant forms (I.1.2.1). After which, all outstanding fees applicable to the preceding years of study must be paid in full, together with the minimum registration fee applicable for registration, before registration will take place.

### **I.1.2.11 Extension of study period**

A student who does not expect to complete the curriculum within the maximum study period must apply (on the prescribed form) for an extension of the study period for one academic year before the end of the maximum allowed period of study (in accordance with Academic Rule A.4.4.10 and A.5.4.10).

The study leader makes a recommendation to the School Director with regard to extension of the study period. Please consult the postgraduate e-Fundi site for the necessary procedures to follow and forms to be completed – website: <http://efundi.nwu.ac.za/portal/>.

### **I.1.2.12 Registration for additional modules**

A postgraduate student may upon request, but subject to Faculty Rules, be allowed in any study year to register for additional modules not required for the curriculum concerned. Additional fees will be applicable.

### **I.1.2.13 Recognition of and exemption from modules**

According to the Academic Rules, a student who joins the University after having completed only a portion of or a full qualification at another institution of higher learning may, with a view to further study at this University, apply in writing for recognition of modules, provided that exemption shall not be granted for more than half the number of modules required for the curriculum. The student may repeat modules from which he/she cannot be exempted.

Any registered student of this University who wishes to change a curriculum during the course of his/her study period may, with a view to further study at this University, apply in writing to the appropriate faculty for recognition of any modules that he/she has already passed and which forms part of the curriculum to which the student wishes to change.

#### **I.1.2.14 Research proposal and title registration for master's and doctoral degrees**

Master's and doctoral students must after registration (and in consultation with a study leader) present a research proposal and title registration for approval to a body determined by Faculty Rules. If a student fails to present a research proposal for approval in time after due notification, the study may be terminated.

If, in any year, a student fails to re-register as student at the time determined in the annual calendar, the Faculty Board concerned may assign the topic of the dissertation or thesis, if already registered, to another student in the same research entity.

#### **I.1.2.15 Classification of dissertations and theses**

Where a dissertation or thesis is classified in terms of Senate Policy, effect is given in the examination process to the rules laid down by Senate for the purpose.

The postgraduate student and study leader(s) concerned are responsible for applying for classification in a timeous manner by completing the required forms. Please consult the postgraduate e-Fundi site for the necessary procedures to follow and forms to complete – website: <http://efundi.nwu.ac.za/portal/> or [www.nwu.ac.za](http://www.nwu.ac.za).

#### **I.1.2.16 Upgrade of master's degree study to doctoral study**

Academic Rule A.4.4.9. stipulates that a student who is registered for a master's degree and who, in the unanimous opinion of the study leader concerned, the Research Director or research entity leader concerned, or where applicable, the School Director concerned, has achieved outcomes of quality and extent acceptable for a doctoral degree, may apply to the Faculty Board concerned to convert the registration for a master's degree to that for a doctoral degree.

A candidate to whom such concession is made, must, where applicable, successfully complete the paper component of the master's degree examination before the thesis may be submitted and must comply with all the rules and requirements set by the University regarding a doctoral degree. The student only receives the doctoral degree after the number of credits for the master's degree papers, where applicable, has been attained and the minimum period required for the registration of the doctoral degree has expired.

#### **I.1.2.17 Termination of study**

The Campus Rector concerned may, in terms of the Faculty Rules and on recommendation of the Research Director or the research entity leader concerned, or where applicable, to the School Director concerned, terminate a student's study if the student fails to comply with all the requirements of Senate or the Faculty; or fails to re-register; or exceeds the maximum duration of the study period as determined by Faculty Rules; or after being granted an extended study period, still fails to complete the study.

In the event of an application for re-admission by a student whose study has been terminated, the Dean concerned has the discretionary authority to set reasonable conditions for such re-admission and must report such conditions to the Vice-Rector.

### **I.1.2.18 Examination**

#### **Postgraduate Diploma**

The examination of the Postgraduate Diploma in Nuclear Science and Technology is conducted in accordance with the requirements of Academic Rule A.4.4.

#### **Master's Degrees**

The examination of the master's degree is conducted in accordance with the requirements of Academic Rule A.4.4. The taught course modules should preferably be completed in the first year of study.

#### **Doctoral Degrees**

The examination of the doctoral degree is conducted in accordance with the requirements of Academic Rule A.5.4.

### **I.1.2.19 Submission of dissertation or thesis for examination**

According to Academic Rule A.4.4.2. a dissertation for a master's degree must be submitted for examination before or on the date determined annually by the Senate. The same applies to a thesis for a doctoral degree in terms of Academic Rule A.5.4.2.

In the case where a resubmission result was obtained during the first examination submission, a student must resubmit their dissertation or thesis within 12 months (1 year) of the first submission.

Certain prescribed forms have to be completed before and at submission. Please consult the postgraduate e-Fundi site for the necessary procedures to follow and forms to complete – website: <http://efundi.nwu.ac.za/portal/>.

### **I.1.3 LANGUAGE POLICY**

The University strives towards being internationally relevant by utilizing English as teaching medium, with all postgraduate correspondence and documentation made available to students in English.

### **I.1.4 WARNING AGAINST PLAGIARISM**

Assignments are individual tasks and not group activities (unless explicitly indicated as group activities). The focus of a University is scholarship, the practice of scientific disciplines. Science is discovered/researched, taught, learnt and made useful to satisfy legitimate needs.

Scientific knowledge is constantly disseminated by those who teach and are taught, those who learn and those who render research results. Scientific communication is therefore at the root of the activities of the University.

A distinction between what is scientific and pre-scientific is situated in the way in which scientific information is communicated, regardless of whether this is in the context of learning, teaching, research or application of knowledge. Scientific communication must pass the test of correctness, defensibility and (especially in the case of research) originality. The scientific practice of students and scientists is adjudicated and evaluated on an ongoing basis. For that reason, integrity and therefore honesty, apart from obvious moral considerations, is an essential factor in the practice of science and scholarship.

It is therefore expected of anybody engaged in scientific work that the relevant individual should assume sole responsibility for the content of his or her scientific communication. To present at any level as one's own work the knowledge, insights, wording or formulation of anybody else within the context of teaching, learning, research activities or the application of knowledge without acknowledgement is unacceptable and the blameworthiness is comparable with crimes such as theft and fraud.

Dishonest academic conduct constitutes serious misconduct, whether it occurs orally, by conduct, or in writing, during examinations or in the context of other forms of assessment such as assignments, dissertations, theses, as well as in reports and publications.

Therefore it is the policy of the North-West University that no form of academic dishonesty shall be tolerated, and if any of such conduct is reported or detected, the perpetrator, upon being found guilty, shall be punishable in terms of the University's disciplinary policies, rules and procedures. The University has the responsibility to inculcate integrity and its corollary of academic honesty in all students and staff, especially those in academic positions.

For further details see:

[http://www.puk.ac.za/beheer-bestuur/beleid-reels/index\\_e.html](http://www.puk.ac.za/beheer-bestuur/beleid-reels/index_e.html)

### **I.1.5 CAPACITY STIPULATION**

Please take cognizance of the fact that, owing to specific capacity constraints, the University reserves the right to select candidates for admission to certain fields of study. This means that prospective students who comply with the minimum requirements may not necessarily be admitted to the relevant courses.

### **I.1.6 SCHOOLS OF THE FACULTY**

Postgraduate academic programmes are presented within the Faculty of Engineering's three Schools and one off-campus centre. The Schools are responsible for the undergraduate and postgraduate academic training of students.

The Centre for Research and Continued Engineering Development (CRCED) exist off-campus to cater for needs of postgraduate students in the Gauteng area.

The master's taught course modules are presented and managed by the three Schools. CRCED Pretoria offers supervision for master's students in some of the disciplines offered by the Faculty. In the coordination and presentation of postgraduate training programmes, the Directors of the Schools are assisted by Postgraduate Programme Managers and by the Postgraduate Administrative Manager.

<b>Schools</b>
School of Chemical and Minerals Engineering
School of Electrical, Electronic and Computer Engineering
School of Mechanical and Nuclear Engineering
Centre of Research and Continued Engineering Development (Pretoria)

## I.1.7

## QUALIFICATIONS, PROGRAMMES AND CURRICULA

DIPLOMAS					
Qualification	Qualification and Qualification Code	Curriculum and Curriculum Code		Method of delivery	NQF level
Postgraduate Diploma in Nuclear Science and Technology	705 100	I501P		Full-time Part-time	8
MASTER'S DEGREES					
Qualification	Qualification and Qualification Code	Curriculum and Curriculum Code		Method of delivery	NQF level
Master of Engineering (MEng)	Chemical 702 110	Option A (Dissertation - full) I871P	Option B (Dissertation) I872P	Full-time Part-time	9
	Computer and Electronic 702 109	Option A (Dissertation - full) I886P	Option B (Dissertation) I887P	Full-time Part-time	9
	Development and Management 702 111	Option A (Dissertation - full) I891P	Option B (Dissertation) I892P	Full-time Part-time	9
	Electrical and Electronic 702 108	Option A (Dissertation - full) I883P	Option B (Dissertation) I884P	Full-time Part-time	9
	Mechanical 702 107	Option A (Dissertation - full) I880P	Option B (Dissertation) I881P	Full-time Part-time	9
	Nuclear 702 104	N/A	Option B (Dissertation) I803P	Full-time Part-time	9
Master of Science in Engineering Sciences (MSc)	Chemical 203 152	Option A (Dissertation - full) I890P	Option B (Dissertation) I891P	Full-time Part-time	9
	Computer and Electronic 203 154	Option A (Dissertation - full) I896P	Option B (Dissertation) I897P	Full-time Part-time	9
	Electrical and Electronic 203 153	Option A (Dissertation - full) I893P	Option B (Dissertation) I894P	Full-time Part-time	9
	Mechanical 203 151	Option A (Dissertation - full) I887P	Option B (Dissertation) I888P	Full-time Part-time	9
	Nuclear 203 200	N/A	Option B (Dissertation) I803P	Full-time Part-time	9

<b>DOCTORATES</b>				
<b>Qualification</b>	<b>Qualification and Qualification Code</b>	<b>Curriculum and Curriculum Code</b>	<b>Method of delivery</b>	<b>NQF level</b>
Philosophiae Doctor ( <i>PhD</i> )	Chemical Engineering <b>703 104</b>	<b>1901P</b>	Full-time Part-time	10
	Computer Engineering <b>703 113</b>	<b>1910P</b>	Full-time Part-time	10
	Computer and Electronic Engineering <b>703 109</b>	<b>1906P</b>	Full-time Part-time	10
	Development and Management Engineering <b>703 111</b>	<b>1908P</b>	Full-time Part-time	10
	Electrical Engineering <b>703 105</b>	<b>1902P</b>	Full-time Part-time	10
	Electronic Engineering <b>703 106</b>	<b>1903P</b>	Full-time Part-time	10
	Electrical and Electronic Engineering <b>703 108</b>	<b>1905P</b>	Full-time Part-time	10
	Engineering Science <b>703 110</b>	<b>1907P</b>	Full-time Part-time	10
	Mechanical Engineering <b>703 107</b>	<b>1904P</b>	Full-time Part-time	10
	Nuclear Engineering <b>703 112</b>	<b>1909P</b>	Full-time Part-time	10

## **I.1.8 RULES FOR THE POSTGRADUATE DIPLOMA**

### **I.1.8.1 Duration (minimum and maximum duration)**

The minimum term of study is **one year** and the maximum term of study is **two years**.

### **I.1.8.2 Admission requirements for the qualification**

Refer to the programme and Faculty-specific information (I.1.2) in this Calendar for information regarding admission requirements.

### **I.1.8.3 Method of presentation**

The modules are presented by means of a distance-contact method. The e-learning platform e-Fundi, with an interactive site for each module, enables students to participate in well-structured self-study learning activities prior to attending the contact lecture session.

Six to eight weeks, of which one week is a contact session, are scheduled for each module. Students cannot register for more than two modules being presented simultaneously, except the Nuclear Engineering Project.

All lectures of a specific module are given during one week. The other weeks are used for self-study, assignments and assessment. During this period students have access to a facilitator who will provide support as required.

### **I.1.8.4 Postgraduate Diploma in Nuclear Science and Technology Qualification Code: 705 100**

This programme provides learners with:

- a wider and deeper knowledge of nuclear science;
- advanced training in the field of nuclear science and technology;
- problem-solving ability;
- integration of knowledge across fields;
- the ability to execute a project in the field of nuclear science and technology.

#### **I.1.8.4.1 Admission requirements for the programme**

- Three-year BSc degree (with Mathematics or Physics to at least the second year);
- BTech (Engineering).

Enquiries with regard to these curricula should be directed to the Director: School of Mechanical and Nuclear Engineering at telephone (018) 299 4283.

#### I.1.8.4.2 List of modules

Module code	Descriptive name	Prerequisites	Credits
NUCI 511	Nuclear Engineering I	-	16
NUCI 521	Introduction to Thermal-Fluid Sciences	-	16
NUCI 571	Mathematics for Nuclear Engineers	-	16
NUCI 572	Nuclear Reactor Technology	-	16
NUCI 573	Nuclear Reactor Safety	-	16
NUCI 574	Nuclear Engineering Project	-	16
NUCI 575	Nuclear Physics	-	16
NUCI 576	Radiation and the Environment	-	16

*\* The School reserves the right not to offer certain modules during a certain year.*

#### I.1.8.5 Curriculum: I501P

##### I.1.8.5.1 Curriculum outcomes

The Postgraduate Diploma in Nuclear Science and Technology pursues knowledge and innovation in the field of nuclear power generation and develops and empowers graduates to think laterally and critically and to serve the country specifically within the fields of power generation.

##### I.1.8.5.2 Compilation of curriculum

The curriculum is constituted of 4 core modules, 3 fundamental modules and a project report. Each of these modules and the report counts 16 credits for a total of 128 credits for the diploma.

One credit represents 10 notional study hours, so a prospective student should expect to spend at least 1280 study hours on the programme.

Information regarding the course schedule, lecture venue, structure of the courses, etc. can be obtained from the School of Mechanical and Nuclear Engineering, at telephone (018) 285 2512.

Components	Composition	Credits
Project Report	Core (Compulsory)	16
4 Modules	Core (Compulsory)	16 ea.
3 Modules	Fundamental (Compulsory)	16 ea.
<b>Total credits for the curriculum</b>		<b>128</b>



## I.1.9 RULES FOR THE DEGREE MASTER OF ENGINEERING

### I.1.9.1 Duration (minimum and maximum duration)

The minimum **full-time** term of study is **one year** and the maximum is **two years**.

For **part-time** study the minimum term is **one year** and the maximum term is **three years**, calculated from the beginning of the first year of registration for the relevant programme.

### I.1.9.2 Admission requirements for the qualification

- The student holds an applicable four-year bachelor degree (ECSA-accredited) in engineering or has been allowed to that status.

The School Director may, with notification to the Faculty Management Committee (postgraduate), request students who do not comply with the abovementioned requirements to be provisionally registered for the MEng-degree on the grounds of knowledge and experience gained through prior learning, pending the Recognition of Prior Learning outcome. Refer to I.1.2.1. for the RPL-process to be followed for consideration of non-provisional registration.

Programme-specific assumptions are, where applicable, indicated at each programme description.

### I.1.9.3 Composition of the programme

The master's degree programme allows for two options. These options allow different combinations of coursework and/or research that are based on an engineering problem leading to a synthesized solution based on engineering methods and designs.

The two options can be summarized as follows:

Option A		Option B		Option B (Nuclear)	
Description	Credits	Description	Credits	Description	Credits
Dissertation ( <i>full</i> )	180	Dissertation	100	Dissertation	100
		5x elective modules	16 ea.	3x compulsory modules	16 ea.
				2x elective modules	16 ea.
<b>Total</b>	<b>180</b>	<b>Total</b>	<b>180</b>	<b>Total</b>	<b>180</b>

\* **Note:** At least three (3) of the five (5) 16-credit taught course modules must be engineering technology modules within the chosen curriculum.

#### I.1.9.3.1 Option A (Comprehensive research dissertation)

To provide specialist knowledge in a chosen field and advanced competence in research methodology.

##### Outcomes

The programme outcomes have been achieved if the student demonstrates competence in applying research methodology as evidenced by a dissertation with proper structure, style and language that includes:

- Identification of the research problem and formulation of clear objectives for the study;

- A critical, relevant and comprehensive literature survey;
- Development of the necessary research procedures and experimental facilities/numerical models;
- Execution of either an empirical or numerical investigation to address the research problem;
- Verification and validation of the results;
- Assessment of the results; and
- Conclusions, generalizations and recommendations.

#### I.1.9.3.2

##### **Option B (Coursework and a dissertation)**

To provide specialist knowledge in a chosen field and advanced competence in research methodology.

##### **Outcomes**

The programme outcomes have been achieved if the student demonstrates competence in applying specialized knowledge in a chosen field as evidenced by coursework assessment that includes:

- Application of specialized tools and techniques;
- Higher level problem solving and engineering synthesis;
- Integration of knowledge across fields.

The student is competent in applying research methodology or advanced design and/or investigative skills as evidenced by a dissertation with proper structure, style and language that includes:

- Identification of the research or engineering problem and formulation of clear objectives for the study;
- A critical and relevant literature survey;
- Development of the necessary research or design/investigative procedures and experimental facilities/numerical models;
- Execution of a comprehensive design or investigation to address the problem;
- Verification of the results;
- Assessment of the results; and
- Conclusions.

#### I.1.9.4

##### **Requirements for a dissertation**

Regarding technical requirements, a dissertation must comply with all requirements and outcomes laid down by the Faculty. Also see the Manual for Postgraduate Studies and the applicable A-Rules in this regard.

For presenting a dissertation in the form of a published research article(s) or (an) unpublished manuscript(s) in article format, see Academic Rule A.4.4.2.9. and the Manual for Postgraduate Studies (3.10).

### **I.1.9.5 Faculty-specific requirements**

The title of the dissertation, the research proposal and the appointment of external examiners must be reviewed by the Faculty Management Committee (postgraduate). Further information regarding rules and procedures are contained in the Faculty-specific rules I.1.2.14., Academic Rules A.4.3.1. and A.4.4., and in the Manual for Postgraduate Study.

In addition to attaining the abovementioned outcomes, students are also required to:

- take part in at least two formal colloquia and/or technical conferences where aspects of their work are presented to an audience of peers;
- have at least one full-length research paper on aspects of the dissertation submitted for review/publication in an accredited scientific journal before being allowed to submit the dissertation for examination (A.4.4.2.8.).

Official prescribed forms used in the postgraduate study process are available on the postgraduate e-Fundi site – website: <http://efundi.nwu.ac.za/portal/>.

Refer to the programme-specific information in this Calendar for information regarding the Faculty-specific requirements.

### **I.1.9.6 Articulation possibilities**

- After the successful completion of the MEng programme, graduates who have performed adequately may be allowed to continue with a doctoral programme in the core module/programme in which the qualification has been awarded.
- Credit will be given to modules passed at other faculties or institutes of higher education, with final approval from the Faculty Management Committee (postgraduate), provided the student fully complies with the outcome and total credit requirements for this qualification/programme.
- The expertise that the graduate acquires with this qualification in one of the engineering disciplines will empower him/her to continue with further learning and research in various other specialized fields at a variety of institutions.

### **I.1.9.7 List of modules**

Although the research and research modules are managed by the Unit for Engineering Research, the taught course modules are managed by the respective Schools. Curricula are listed under the Schools or Units in which they are presented for easy reference.

*Note: CRCED Pretoria offers supervision in a variety of the available study areas*

The total number of credits needed to obtain an MEng in Engineering degree is 180 credits. Each credit represents a nominal of 10 hours of study. Students choose one curriculum with certain taught course modules to be completed in order to obtain the relevant degree. The taught course modules approved as part of the master's degree curricula in the Faculty of Engineering are listed below.

<b>UNIT FOR ENGINEERING RESEARCH</b>		
<b>Module code</b>	<b>Descriptive name</b>	<b>Credits</b>
CEMI 871	Dissertation ( <i>full</i> )	180
CEMI 872	Dissertation	100
EERI 871	Dissertation ( <i>full</i> )	180
ELEI 872	Dissertation	100
REEI 872	Dissertation	100
MEGI 871	Dissertation ( <i>full</i> )	180
MEGI 872	Dissertation	100
NUCI 872	Dissertation	100
IIOB 871	Dissertation ( <i>full</i> )	180
IIOB 872	Dissertation	100
<b>SCHOOL OF CHEMICAL AND MINERALS ENGINEERING</b>		
<b>Module code</b>	<b>Descriptive name</b>	<b>Credits</b>
CEMI 875	Fluid-phase Equilibrium	16
CEMI 876	Separation Processes	16
CEMI 877	Coal Technology I	16
CEMI 878	Coal Technology II	16
CEMI 879	Bioreactors and Bioprocess Technology	16
CEMI 881	Bio-ethanol Process Technology	16
CEMI 882	STS and Renewable Energy	16
CEMI 883	Introduction to Renewable and Sustainable Energy	16
CEMI 884	Biodiesel Process Technology	16
<b>SCHOOL OF ELECTRICAL, ELECTRONIC AND COMPUTER ENGINEERING</b>		
<b>Module code</b>	<b>Descriptive name</b>	<b>Credits</b>
EEII 881	Data Mining and Knowledge Extraction	16
EEII 882	Electrical Power Quality	16
EEII 883	Advanced Protection Systems	16
EEII 884	Advanced Signal Processing	16
EEII 885	Information Systems for e-trade and e-logistics	16
EEII 886	Information Security: Strategies and Techniques	16
EEII 887	Kalman Filters	16
EEII 888	Power System Dynamics	16
EEII 889	Compensation of Distortion in Power Systems	16
EEII 891	Advanced Electronic Development and Design	16
EEII 892	Advanced Power Electronics	16
EEII 893	Advanced Electrical Machines	16
EERI 877	Digital Control Systems	16
ERIE 874	Neural Networks	16
ERIE 875	Fuzzy Logic Systems	16
ERIE 876	Process Modelling and Identification	16
<b>SCHOOL OF MECHANICAL AND NUCLEAR ENGINEERING</b>		
<b>Module code</b>	<b>Descriptive name</b>	<b>Credits</b>
MEGI 874	Computational Fluid Dynamics I	16
MEGI 875	Computational Fluid Dynamics II	16
MEGI 876	Finite Element Methods	16
MEGI 877	Finite Element Methods for Flow	16
MEGI 878	Energy Management	16
MEGI 879	Advanced Engineering Thermodynamics	16
MEGI 884	Advanced Strength of Materials	16

MEGI 889	Materials Selection for Design	16
MEGI 894	Composite Materials	16
MGII 885	Thermal-Fluid Systems Modelling I	16
MGII 886	Thermal-Fluid Systems Modelling II	16
MGII 887	Gas Turbine Theory and Performance	16
NUCI 621	Introduction to Thermal-Fluid Sciences	16
NUCI 671	Mathematics for Nuclear Engineers	16
NUCI 811	Nuclear Engineering I	16
NUCI 874	Advanced Reactor Analysis I	16
NUCI 876	High Temperature Gas-Cooled Reactor Thermal-Fluid Analysis	16
NUCI 877	High Temperature Reactor Fuels and Materials	16
NUCI 878	High Temperature Reactor Technology	16
NUCI 879	Nuclear Project Management	16
NUCI 882	Light Water Reactor Thermal-Hydraulics	16
NUCI 883	Nuclear Engineering II	16
NUCI 886	Pebble Bed Reactor Design	16
NUCI 887	Reactor Analysis	16
NUCI 888	Reactor Safety	16
NUCI 889	Pressurized Water Reactor Technology	16
IIOB 881	Project Management	16
IIOB 882	Maintenance Management	16
IIOB 883	Corporate Career Skills	16
IIOB 884	Production Optimization Management	16
IIOB 885	Entrepreneurial Career Skills	16
IIOB 886	System Engineering	16
IIOB 887	Quality Management in Engineering Projects	16

### **I.1.9.8 Course modules from other MEng and/or other curricula**

Any postgraduate taught course module in any School in the Faculty of Engineering or complementary modules offered by any other Faculty may be chosen after consultation with the appropriate Programme Manager and his/her supervisor, provided that:

- more than 50% of taught course modules are within the chosen curriculum;
- the complimentary taught course modules, as chosen from other master's curricula, are relevant to the proposed research project, pre-approved by the study leader, on a NQF level 9, with the appropriate credits; and
- the supervisor has given permission in writing for the choice of other taught course modules to be taken.

**I.1.9.9 MEng in Chemical Engineering**  
**Qualification Code: 702 110**

**I.1.9.9.1 Admission requirements for the programme**

Refer to the programme and Faculty-specific information (I.1.2.) in this Calendar for information regarding admission requirements.

Enquiries with regard to these curricula to be directed to the Director: School of Chemical and Minerals Engineering at telephone (018) 299 1994.

**I.1.9.9.2 Curriculum Code: I871P**

**Option A**

Module code	Descriptive name	Cr
<b>Compulsory</b>		
CEMI 871	Dissertation ( <i>full</i> )	180
<b>Total credits for the curriculum</b>		<b>180</b>

**I.1.9.9.3 Curriculum Code: I872P**

**Option B**

Module code	Descriptive name	Prerequisites	Cr
<b>Core (Compulsory)</b>			
CEMI 872	Dissertation	-	100
<b>Electives (Choose five – compulsory)</b>			
CEMI 875	Fluid-phase Equilibrium	-	16
CEMI 876	Separation Processes	-	16
CEMI 877	Coal Technology I	-	16
CEMI 878	Coal Technology II	-	16
CEMI 879	Bioreactors and Bioprocess Technology	-	16
CEMI 881	Bio-ethanol Process Technology	-	16
CEMI 882	STS and Renewable Energy	-	16
CEMI 883	Introduction to Renewable and Sustainable Energy	-	16
CEMI 884	Biodiesel Process Technology	-	16
<b>Total credits for the curriculum</b>			<b>180</b>

*\* The School reserves the right not to offer certain modules during a certain year.*

**I.1.9.10 MEng in Computer and Electronic Engineering**  
**Qualification Code: 702 109**

**I.1.9.10.1 Admission requirements for the programme**

Refer to the programme and Faculty-specific information (I.1.2.) in this Calendar for information regarding admission requirements.

Enquiries with regard to these curricula should be directed to the Director: School of Electrical, Electronic and Computer Engineering at telephone (018) 299 1970.

**I.1.9.10.2 Curriculum Code: I886P**  
**Option A**

Module code	Descriptive name	Cr
<b>Compulsory</b>		
EERI 871	Dissertation ( <i>full</i> )	180
<b>Total credits for the curriculum</b>		<b>180</b>

**I.1.9.10.3 Curriculum Code: I887P**  
**Option B**

Module code	Descriptive name	Prerequisites	Cr
<b>Core (Compulsory)</b>			
REEI 872	Dissertation	-	100
<b>Electives (Choose five – compulsory)</b>			
EELI 881	Data Mining and Knowledge Extraction	-	16
EELI 884	Advanced Signal Processing	-	16
EELI 885	Information Systems for e-trade and e-logistics	-	16
EELI 886	Information Security: Strategies and Techniques	-	16
EELI 887	Kalman Filters	-	16
EELI 891	Advanced Electronic Development and Design	-	16
EERI 877	Digital Control Systems	-	16
ERIE 874	Neural Networks	-	16
ERIE 875	Fuzzy Logic Systems	-	16
ERIE 876	Process Modelling and Identification	-	16
<b>Total credits for the curriculum</b>			<b>180</b>

*\* The School reserves the right not to offer certain modules during a certain year.*

**I.1.9.11 MEng in Electrical and Electronic Engineering**  
**Qualification Code: 702 108**

**I.1.9.11.1 Admission requirements for the programme**

Refer to the programme and Faculty-specific information (I.1.2.) in this Calendar for information regarding admission requirements.

Enquiries with regard to these curricula should be directed to the Director: School of Electrical, Electronic and Computer Engineering at telephone (018) 299 1970.

**I.1.9.11.2 Curriculum Code: I883P**  
**Option A**

Module code	Descriptive name	Cr
<b>Compulsory</b>		
EERI 871	Dissertation ( <i>full</i> )	180
<b>Total credits for the curriculum</b>		<b>180</b>

**I.1.9.11.3 Curriculum Code: I884P**  
**Option B**

Module code	Descriptive name	Prerequisites	Cr
<b>Core (Compulsory)</b>			
ELEI 872	Dissertation	-	100
<b>Electives (Choose five – compulsory)</b>			
EELI 882	Electrical Power Quality	-	16
EELI 883	Advanced Protection Systems	-	16
EELI 884	Advanced Signal Processing	-	16
EELI 887	Kalman Filters	-	16
EELI 888	Power System Dynamics	-	16
EELI 889	Compensation of Distortion in Power Systems	-	16
EELI 891	Advanced Electronic Development and Design	-	16
EELI 892	Advanced Power Electronics	-	16
EELI 893	Advanced Electrical Machines	-	16
EERI 877	Digital Control Systems	-	16
ERIE 874	Neural Networks	-	16
ERIE 875	Fuzzy Logic Systems	-	16
ERIE 876	Process Modelling and Identification	-	16
<b>Total credits for the curriculum</b>			<b>180</b>

\* The School reserves the right not to offer certain modules during a certain year.



**I.1.9.12 MEng in Mechanical Engineering****Qualification Code: 702 107****I.1.9.12.1 Admission requirements for the programme**

Refer to the programme and Faculty-specific information (I.1.2.) in this Calendar for information regarding admission requirements.

Enquiries with regard to these curricula should be directed to the Director: School of Mechanical and Nuclear Engineering at telephone (018) 299 4283.

**I.1.9.12.2 Curriculum Code: I880P****Option A**

Module code	Descriptive name	Cr
<b>Compulsory</b>		
MEGI 871	Dissertation ( <i>full</i> )	180
<b>Total credits for the curriculum</b>		<b>180</b>

**I.1.9.12.3 Curriculum Code: I881P****Option B**

Module code	Descriptive name	Prerequisites	Cr
<b>Core (Compulsory)</b>			
MEGI 872	Dissertation	-	100
<b>Electives (Choose five – compulsory)</b>			
MEGI 874	Computational Fluid Dynamics I	-	16
MEGI 875	Computational Fluid Dynamics II	MEGI 874	16
MEGI 876	Finite Element Methods	-	16
MEGI 877	Finite Element Methods for Flow	-	16
MEGI 878	Energy Management	-	16
MEGI 879	Advanced Engineering Thermodynamics	-	16
MEGI 884	Advanced Strength of Materials	-	16
MEGI 889	Materials Selection for Design	-	16
MEGI 894	Composite Materials	-	16
MGII 885	Thermal-Fluid Systems Modelling I	-	16
MGII 886	Thermal-Fluid Systems Modelling II	MGII 885	16
MGII 887	Gas Turbine Theory and Performance	-	16
<b>Total credits for the curriculum</b>			<b>180</b>

\* The School reserves the right not to offer certain modules during a certain year.

**I.1.9.13 MEng in Nuclear Engineering**  
**Qualification Code: 702 104**

**I.1.9.13.1 Admission requirements for the programme**

Refer to the programme and Faculty-specific information (I.1.2.) in this Calendar for more information regarding admission requirements.

Nuclear Engineering modules are presented on a focused contact basis. Instruction is provided as a series of continuous contact sessions, followed by assignments and examinations. This requires students to attend lectures for a number of consecutive days as specified per module.

Enquiries with regard to these curricula should be directed to the Director: School of Mechanical and Nuclear Engineering at telephone (018) 299 4283.

**I.1.9.13.2 Faculty-specific requirements**

- Students in possession of either a **BEng (Mechanical)** or **BEng (Chemical)** degree must register for Mathematics for Nuclear Engineers (**NUCI 671**), which is a **bridging module**.
- Students in possession of a **BEng (Electrical/Electronic)** must register for Mathematics for Nuclear Engineers (**NUCI 671**) and Introduction to Thermal-Fluid Sciences (**NUCI 621**), which are **bridging modules**.

*\* The credits for the two bridging modules do not count towards the 180 credits for the master's degree.*

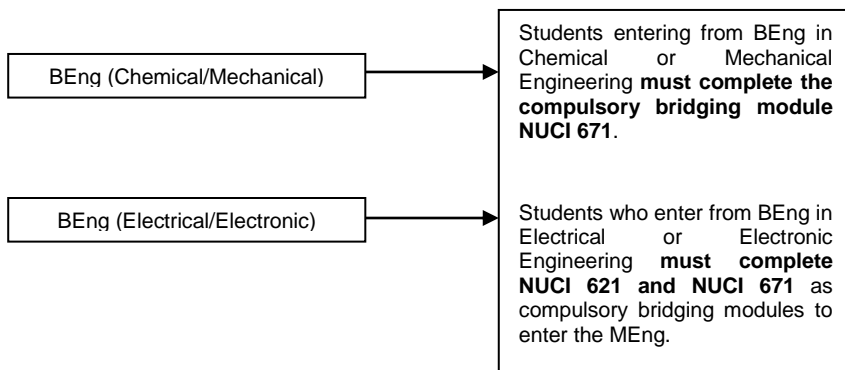

I.1.9.13.3 Curriculum Code: I803P

Option B

Module code	Descriptive name	Prerequisites	Cr
<b>Core (Compulsory)</b>			
NUCI 872	Dissertation	-	100
NUCI 811	Nuclear Engineering I	-	16
NUCI 883	Nuclear Engineering II	NUCI 811 NUCI 621* NUCI 671*	16
NUCI 887	Reactor Analysis	NUCI 883	16
<b>Electives (Choose two – compulsory)</b>			
NUCI 882	Light Water Reactor Thermal-Hydraulics	NUCI 883 MGII 885	16
NUCI 886	Pebble Bed Reactor Design	NUCI 883 NUCI 874	16
NUCI 888	Reactor Safety	NUCI 883 NUCI 887	16
NUCI 889	Pressurized Water Reactor Technology	NUCI 883 NUCI 887	16
NUCI 874	Advanced Reactor Analysis I	NUCI 887	16
NUCI 876	High Temperature Gas-Cooled Reactor Thermal-Fluid Analysis	NUCI 883 MEGI 874	16
NUCI 877	High Temperature Reactor Fuels and Materials	NUCI 883 NUCI 887	16
NUCI 878	High Temperature Reactor Technology	NUCI 883 NUCI 887	16
NUCI 879	Nuclear Project Management	-	16
MEGI 874	Computational Fluid Dynamics I	MGII 885	16
MGII 885	Thermal-Fluid Systems Modelling I	NUCI 621	16
MGII 886	Thermal-Fluid Systems Modelling II	MGII 885	16
IIOB 886	System Engineering	-	16
<b>Total credits for the curriculum</b>			<b>180</b>

\* Refer to I.1.8.12.2

\*\* The School reserves the right not to offer certain modules during a certain year.

**I.1.9.14 MEng in Development and Management Engineering**  
**Qualification Code: 702 111**

**I.1.9.14.1 Admission requirements for the programme**

Refer to the programme and Faculty-specific information (I.1.2.) in this Calendar for information regarding admission requirements.

Enquiries with regard to these curricula should be directed to the Director: School of Mechanical and Nuclear Engineering at telephone (018) 299 4283.

**I.1.9.14.2 Curriculum Code: I891P**

**Option A**

Module code	Descriptive name	Cr
<b>Compulsory</b>		
IIOB 871	Dissertation ( <i>full</i> )	180
<b>Total credits for the curriculum</b>		<b>180</b>

**I.1.9.14.3 Curriculum Code: I892P**

**Option B**

Module code	Descriptive name	Prerequisites	Cr
<b>Core (Compulsory)</b>			
IIOB 872	Dissertation	-	100
<b>Electives (Choose five – compulsory)</b>			
IIOB 881	Project Management	-	16
IIOB 882	Maintenance Management	-	16
IIOB 883	Corporate Career Skills	-	16
IIOB 884	Production Optimization Management	-	16
IIOB 885	Entrepreneurial Career Skills	-	16
IIOB 886	System Engineering	-	16
IIOB 887	Quality Management in Engineering Projects	-	16
<b>Total credits for the curriculum</b>			<b>180</b>

\* The School reserves the right not to offer certain modules during a certain year.

## I.1.10 RULES FOR THE DEGREE MASTER OF SCIENCE IN ENGINEERING SCIENCES

### I.1.10.1 Duration (minimum and maximum duration)

The minimum **full-time** term of study is **one year** and the maximum is **two years**.

For **part-time** study the minimum term is **one year** and the maximum term is **three years**, calculated from the beginning of the first year of registration for the relevant programme.

### I.1.10.2 Admission requirements for the qualification

The MSc-degree in Engineering Science may follow on a

- BSc (Hons) degree;
- applicable four-year bachelor degree (ECSA-accredited) in engineering or the student has been allowed to that status;
- another recognized qualification that allows the student to attain equivalent status and which has approved by the Postgraduate Research Quality Assurance Committee.

The School Director may, with notification to the Faculty Management Committee (postgraduate), request students who do not comply with the abovementioned requirements to be provisionally registered for the MSc-degree on the grounds of knowledge and experience gained through prior learning, pending the Recognition of Prior Learning outcome. Refer to I.1.2.1. for the RPL-process to be followed for consideration of non-provisional registration.

Programme-specific assumptions are, where applicable, indicated at each programme description.

### I.1.10.3 Composition of the programme

The master's degree programme allows for two options. These options allow different combinations of coursework and/or research that are based on an engineering problem leading to a synthesized solution based on engineering methods and designs.

The two options can be summarized as follows:

Option A		Option B		Option B (Nuclear)	
Description	Credits	Description	Credits	Description	Credits
Dissertation ( <i>full</i> )	180	Dissertation	100	Dissertation	100
		5x elective modules	16 ea.	3x compulsory modules	16 ea.
				2x elective modules	16 ea.
<b>Total</b>	<b>180</b>	<b>Total</b>	<b>180</b>	<b>Total</b>	<b>180</b>

\* **Note:** At least three (3) of the five (5) 16-credit taught course modules must be engineering technology modules within the chosen curriculum.

#### **I.1.10.3.1 Option A (Comprehensive Research Dissertation)**

To provide specialist knowledge in a chosen field and advanced competence in research methodology.

##### **Outcomes**

The programme outcomes have been achieved if the student demonstrates competence in applying research methodology as evidenced by a dissertation with proper structure, style and language that includes:

- Identification of the research problem and formulation of clear objectives for the study;
- A critical, relevant and comprehensive literature survey;
- Development of the necessary research procedures and experimental facilities/numerical models;
- Execution of either an empirical or numerical investigation to address the research problem;
- Verification and validation of the results;
- Assessment of the results; and
- Conclusions, generalizations and recommendations.

#### **I.1.10.3.2 Option B (Coursework and a dissertation)**

To provide specialist knowledge in a chosen field and advanced competence in research methodology.

##### **Outcomes**

The programme outcomes have been achieved if the student demonstrates competence in applying specialized knowledge in a chosen field as evidenced by coursework assessment that includes:

- Application of specialized tools and techniques;
- Higher level problem solving and engineering synthesis;
- Integration of knowledge across fields.

The student is competent in applying research methodology or advanced design and/or investigative skills as evidenced by a dissertation with proper structure, style and language that includes:

- Identification of the research or engineering problem and formulation of clear objectives for the study;
- A critical and relevant literature survey;
- Development of the necessary research or design/investigative procedures and experimental facilities/numerical models;
- Execution of a comprehensive design or investigation to address the problem;
- Verification of the results;
- Assessment of the results; and

- Conclusions.

#### **I.1.10.4 Requirements for a dissertation**

Regarding technical requirements, a dissertation must comply with all requirements and outcomes laid down by the Faculty. Also see the Manual for Postgraduate Studies and the applicable A-Rules in this regard.

For presenting a dissertation in the form of a published research article(s) or (an) unpublished manuscript(s) in article format, see Academic Rule A.4.4.2.9. and the Manual for Postgraduate Studies (3.10).

#### **I.1.10.5 Faculty-specific requirements**

The title of the dissertation, the research proposal and the appointment of external examiners must be reviewed by the Faculty Management Committee (postgraduate). Further information regarding rules and procedures are contained in the Faculty-specific rules I.1.2.14., Academic Rules A.4.3.1. and A.4.4., and in the Manual for Postgraduate Study.

In addition to attaining the abovementioned outcomes, students are also required to:

- take part in at least two formal colloquia and/or technical conferences where aspects of their work are presented to an audience of peers;
- have at least one full-length research paper on aspects of the dissertation submitted for review/publication in an accredited scientific journal before being allowed to submit the dissertation for examination (A.4.4.2.8.).

Official prescribed forms used in the postgraduate study process are available on the postgraduate e-Fundi site – website: <http://efundi.nwu.ac.za/portal/>.

Refer to the programme-specific information in this Calendar for information regarding the Faculty-specific requirements.

#### **I.1.10.6 Articulation possibilities**

- After the successful completion of the MSc programme, graduates who have performed adequately may be allowed to continue with a doctoral programme in the core module/programme in which the qualification has been awarded.
- Credit will be given for modules passed at other faculties or institutes of higher education, with final approval from the Faculty Management Committee (postgraduate), provided the outcome and total credit requirements for this qualification/programme have been fully complied with.
- The expertise that the graduate acquires with this qualification in one of the engineering disciplines will empower him/her to continue with further learning and research in various other specialized fields at a variety of institutions.

#### **I.1.10.7 List of modules**

Although the research and research modules are managed by the Unit for Engineering Research, the taught course modules are managed by the

respective Schools. Curricula are listed under the Schools or Units in which they are presented for easy reference.

*Note: CRCED Pretoria offers supervision in a variety of the available study areas*

The total number of credits needed to obtain an MSc in Engineering Sciences degree is 180 credits. Each credit represents a nominal of 10 hours of study. Students choose one curriculum with certain taught course modules to be completed in order to obtain the relevant degree. The taught course modules approved as part of the master's degree curricula in the Faculty of Engineering are listed below.

<b>UNIT FOR ENGINEERING RESEARCH</b>		
<b>Module code</b>	<b>Descriptive name</b>	<b>Credits</b>
CEMI 871	Dissertation ( <i>full</i> )	180
CEMI 872	Dissertation	100
EERI 871	Dissertation ( <i>full</i> )	180
ELEI 872	Dissertation	100
REEI 872	Dissertation	100
MEGI 871	Dissertation ( <i>full</i> )	180
MEGI 872	Dissertation	100
NUCI 872	Dissertation	100
<b>SCHOOL OF CHEMICAL AND MINERALS ENGINEERING</b>		
<b>Module code</b>	<b>Descriptive name</b>	<b>Credits</b>
CEMI 875	Fluid-phase Equilibrium	16
CEMI 876	Separation Processes	16
CEMI 877	Coal Technology I	16
CEMI 878	Coal Technology II	16
CEMI 879	Bioreactors and Bioprocess Technology	16
CEMI 881	Bio-ethanol Process Technology	16
CEMI 882	STS and Renewable Energy	16
CEMI 883	Introduction to Renewable and Sustainable Energy	16
CEMI 884	Biodiesel Process Technology	16
<b>SCHOOL OF ELECTRICAL, ELECTRONIC AND COMPUTER ENGINEERING</b>		
<b>Module code</b>	<b>Descriptive name</b>	<b>Credits</b>
EEII 881	Data Mining and Knowledge Extraction	16
EEII 882	Electrical Power Quality	16
EEII 883	Advanced Protection Systems	16
EEII 884	Advanced Signal Processing	16
EEII 885	Information Systems for e-trade and e-logistics	16
EEII 886	Information Security: Strategies and Techniques	16
EEII 887	Kalman Filters	16
EEII 888	Power System Dynamics	16
EEII 889	Compensation of Distortion in Power Systems	16
EEII 891	Advanced Electronic Development and Design	16
EEII 892	Advanced Power Electronics	16
EEII 893	Advanced Electrical Machines	16
EERI 877	Digital Control Systems	16
ERIE 874	Neural Networks	16
ERIE 875	Fuzzy Logic Systems	16
ERIE 876	Process Modelling and Identification	16



<b>SCHOOL OF MECHANICAL AND NUCLEAR ENGINEERING</b>		
<b>Module code</b>	<b>Descriptive name</b>	<b>Credits</b>
MEGI 874	Computational Fluid Dynamics I	16
MEGI 875	Computational Fluid Dynamics II	16
MEGI 876	Finite Element Methods	16
MEGI 877	Finite Element Methods for Flow	16
MEGI 878	Energy Management	16
MEGI 879	Advanced Engineering Thermodynamics	16
MEGI 884	Advanced Strength of Materials	16
MEGI 889	Materials Selection for Design	16
MEGI 894	Composite Materials	16
MGII 885	Thermal-Fluid Systems Modelling I	16
MGII 886	Thermal-Fluid Systems Modelling II	16
MGII 887	Gas Turbine Theory and Performance	16
NUCI 621	Introduction to Thermal-Fluid Sciences	16
NUCI 671	Mathematics for Nuclear Engineers	16
NUCI 811	Nuclear Engineering I	16
NUCI 874	Advanced Reactor Analysis I	16
NUCI 876	High Temperature Gas-Cooled Reactor Thermal-Fluid Analysis	16
NUCI 877	High Temperature Reactor Fuels and Materials	16
NUCI 878	High Temperature Reactor Technology	16
NUCI 879	Nuclear Project Management	16
NUCI 882	Light Water Reactor Thermal-Hydraulics	16
NUCI 883	Nuclear Engineering II	16
NUCI 886	Pebble Bed Reactor Design	16
NUCI 887	Reactor Analysis	16
NUCI 888	Reactor Safety	16
NUCI 889	Pressurized Water Reactor Technology	16

### **I.1.10.8 Course modules from other MSc and/or other curricula**

Any postgraduate taught course module in any School in the Faculty of Engineering or complementary modules offered by any other Faculty may be chosen after consultation with the appropriate Programme Manager and his/her supervisor, provided that:

- more than 50% of taught course modules are within the chosen curriculum;
- the complimentary taught course modules, as chosen from other master's curricula, are relevant to the proposed research project, pre-approved by the study leader, on a NQF level 9, with the appropriate credits; and
- the supervisor has given permission in writing for the choice of other taught course modules to be taken.

**I.1.10.9 MSc in Chemical Engineering**  
**Qualification Code: 203 152**

**I.1.10.9.1 Admission requirements for the programme**

Refer to the programme and Faculty-specific information (I.1.2.) in this Calendar for information regarding admission requirements.

Enquiries with regard to these curricula should be directed to the Director: School of Chemical and Minerals Engineering at telephone (018) 299 1994.

**I.1.10.9.2 Curriculum Code: I890P**

**Option A**

Module code	Descriptive name	Cr
<b>Compulsory</b>		
CEMI 871	Dissertation ( <i>full</i> )	180
<b>Total credits for the curriculum</b>		<b>180</b>

**I.1.10.9.3 Curriculum Code: I891P**

**Option B**

Module code	Descriptive name	Prerequisites	Cr
<b>Core (Compulsory)</b>			
CEMI 872	Dissertation	-	100
<b>Electives (Choose five – compulsory)</b>			
CEMI 875	Fluid-phase Equilibrium	-	16
CEMI 876	Separation Processes	-	16
CEMI 877	Coal Technology I	-	16
CEMI 878	Coal Technology II	-	16
CEMI 879	Bioreactors and Bioprocess Technology	-	16
CEMI 881	Bio-ethanol Process Technology	-	16
CEMI 882	STS and Renewable Energy	-	16
CEMI 883	Introduction to Renewable and Sustainable Energy	-	16
CEMI 884	Biodiesel Process Technology	-	16
<b>Total credits for the curriculum</b>			<b>180</b>

*\* The School reserves the right not to offer certain modules during a certain year.*

**I.1.10.10 MSc in Computer and Electronic Engineering**  
**Qualification Code: 203 154**

**I.1.10.10.1 Admission requirements for the programme**

Refer to the programme and Faculty-specific information (I.1.2.) in this Calendar for information regarding admission requirements.

Enquiries with regard to these curricula should be directed to the Director: School of Electrical, Electronic and Computer Engineering at telephone (018) 299 1970.

**I.1.10.10.2 Curriculum Code: I896P**

**Option A**

Module code	Descriptive name	Cr
<b>Compulsory</b>		
EERI 871	Dissertation ( <i>full</i> )	180
<b>Total credits for the curriculum</b>		<b>180</b>

**I.1.10.10.3 Curriculum Code: I897P**

**Option B**

Module code	Descriptive name	Prerequisites	Cr
<b>Core (Compulsory)</b>			
REEI 872	Dissertation	-	100
<b>Electives (Choose five – compulsory)</b>			
EELI 881	Data Mining and Knowledge Extraction	-	16
EELI 884	Advanced Signal Processing	-	16
EELI 885	Information Systems for e-trade and e-logistics	-	16
EELI 886	Information Security: Strategies and Techniques	-	16
EELI 887	Kalman Filters	-	16
EELI 891	Advanced Electronic Development and Design	-	16
EERI 877	Digital Control Systems	-	16
ERIE 874	Neural Networks	-	16
ERIE 875	Fuzzy Logic Systems	-	16
ERIE 876	Process Modelling and Identification	-	16
<b>Total credits for the curriculum</b>			<b>180</b>

*\* The School reserves the right not to offer certain modules during a certain year.*

**I.1.10.11 MSc in Electrical and Electronic Engineering**  
**Qualification Code: 203 153**

**I.1.10.11.1 Admission requirements for the programme**

Refer to the programme and Faculty-specific information (I.1.2.) in this Calendar for information regarding admission requirements.

Enquiries with regard to these curricula should be directed to the Director: School of Electrical, Electronic and Computer Engineering at telephone (018) 299 1970.

**I.1.10.11.2 Curriculum Code: I893P**  
**Option A**

Module code	Descriptive name	Cr
<b>Compulsory</b>		
EERI 871	Dissertation ( <i>full</i> )	180
<b>Total credits for the curriculum</b>		<b>180</b>

**I.1.10.11.3 Curriculum Code: I894P**  
**Option B**

Module code	Descriptive name	Prerequisites	Cr
<b>Core (Compulsory)</b>			
ELEI 872	Dissertation	-	100
<b>Electives (Choose five – compulsory)</b>			
EELI 882	Electrical Power Quality	-	16
EELI 883	Advanced Protection Systems	-	16
EELI 884	Advanced Signal Processing	-	16
EELI 887	Kalman Filters	-	16
EELI 888	Power System Dynamics	-	16
EELI 889	Compensation of Distortion in Power Systems	-	16
EELI 891	Advanced Electronic Development and Design	-	16
EELI 892	Advanced Power Electronics	-	16
EELI 893	Advanced Electrical Machines	-	16
EERI 877	Digital Control Systems	-	16
ERIE 874	Neural Networks	-	16
ERIE 875	Fuzzy Logic Systems	-	16
ERIE 876	Process Modelling and Identification	-	16
<b>Total credits for the curriculum</b>			<b>180</b>

\* The School reserves the right not to offer certain modules during a certain year.

**I.1.10.12 MSc in Mechanical Engineering**  
**Qualification Code: 203 151**

**I.1.10.12.1 Admission requirements for the programme**

Refer to the programme and Faculty-specific information (I.1.2.) in this Calendar for information regarding admission requirements.

Enquiries with regard to these curricula to be should be directed to the Director: School of Mechanical and Nuclear Engineering at telephone (018) 299 4283.

**I.1.10.12.2 Curriculum Code: I887P**

**Option A**

Module code	Descriptive name	Cr
<b>Compulsory</b>		
MEGI 871	Dissertation ( <i>full</i> )	180
<b>Total credits for the curriculum</b>		<b>180</b>

**I.1.10.12.3 Curriculum Code: I888P**

**Option B**

Module code	Descriptive name	Prerequisites	Cr
<b>Core (Compulsory)</b>			
MEGI 872	Dissertation	-	100
<b>Electives (Choose five – compulsory)</b>			
MEGI 874	Computational Fluid Dynamics I	-	16
MEGI 875	Computational Fluid Dynamics II	MEGI 874	16
MEGI 876	Finite Element Methods	-	16
MEGI 877	Finite Element Methods for Flow	-	16
MEGI 878	Energy Management	-	16
MEGI 879	Advanced Engineering Thermodynamics	-	16
MEGI 884	Advanced Strength of Materials	-	16
MEGI 889	Materials Selection for Design	-	16
MEGI 894	Composite Materials	-	16
MGII 885	Thermal-Fluid Systems Modelling I	-	16
MGII 886	Thermal-Fluid Systems Modelling II	MGII 885	16
MGII 887	Gas Turbine Theory and Performance	-	16
<b>Total credits for the curriculum</b>			<b>180</b>

\* The School reserves the right not to offer certain modules during a certain year.

**I.1.10.13 MSc in Nuclear Engineering**  
**Qualification Code: 203 200**

**I.1.10.13.1 Admission requirements for the programme**

Refer to the programme and Faculty-specific information (I.1.2.) in this Calendar for more information regarding admission requirements.

- BSc-degree with Mathematics, Applied Mathematics or Physics to at least third year level **plus** a BSc Honours degree in Physics or Mathematics; or
- BTech-degree in Engineering (Mechanical, Chemical or Electrical) **plus** a BSc Honours degree in Physics or Mathematics; or
- Postgraduate Diploma in Nuclear Science and Technology, with a pass average of 65%.

Nuclear Engineering modules are presented on a focused contact basis. Instruction is provided as a series of continuous contact sessions, followed by assignments and examinations. This requires students to attend lectures for a number of consecutive days as specified per module.

Enquiries with regard to these curricula should be directed to the Director: School of Mechanical and Nuclear Engineering at telephone (018) 299 4283.

**I.1.10.13.2 Faculty-specific requirements**

All MSc students must register for the two bridging modules, namely:

- **NUCI 621** – Introduction to Thermal-Fluid Sciences; and
- **NUCI 671** – Mathematics for Nuclear Engineers.

*\* This includes students entering via the Postgraduate Diploma route.*

*\*\* The credits for the two bridging modules do not count towards the 180 credits for the master's degree.*

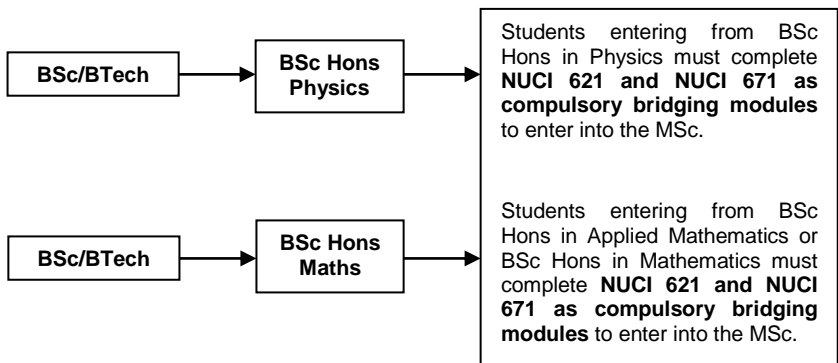

I.1.10.13.3 Curriculum Code: I803P

Option B

Module code	Descriptive name	Prerequisites	Cr
<b>Core (Compulsory)</b>			
NUCI 872	Dissertation	-	100
NUCI 811	Nuclear Engineering I	-	16
NUCI 883	Nuclear Engineering II	NUCI 811 NUCI 621* NUCI 671*	16
NUCI 887	Reactor Analysis	NUCI 883	16
<b>Electives (Choose two – compulsory)</b>			
NUCI 882	Light Water Reactor Thermal-Hydraulics	NUCI 883 MGII 885	16
NUCI 886	Pebble Bed Reactor Design	NUCI 883 NUCI 874	16
NUCI 888	Reactor Safety	NUCI 883 NUCI 887	16
NUCI 889	Pressurized Water Reactor Technology	NUCI 883 NUCI 887	16
NUCI 874	Advanced Reactor Analysis I	NUCI 887	16
NUCI 876	High Temperature Gas-Cooled Reactor Thermal-Fluid Analysis	NUCI 883 MEGI 874	16
NUCI 877	High Temperature Reactor Fuels and Materials	NUCI 883 NUCI 887	16
NUCI 878	High Temperature Reactor Technology	NUCI 883 NUCI 887	16
NUCI 879	Nuclear Project Management	-	16
MEGI 874	Computational Fluid Dynamics I	MGII 885	16
MGII 885	Thermal-Fluid Systems Modelling I	NUCI 621	16
MGII 886	Thermal-Fluid Systems Modelling II	MGII 885	16
IIOB 886	System Engineering	-	16
<b>Total credits for the curriculum</b>			<b>180</b>

\* Refer to I.1.9.12.2

\*\* The School reserves the right not to offer certain modules during a certain year.

## **I.1.11 RULES FOR THE DEGREE OF PHILOSOPHIAE DOCTOR**

The purpose of this programme is to provide opportunity for original research by either uncovering new knowledge and/or by independent and critical analysis of existing information.

### **I.1.11.1 Duration (minimum and maximum duration)**

The minimum **full-time** term of study is **two years** and the maximum is **four years**.

For **part-time** study the minimum term is **two years** and the maximum term is **six years**, calculated from the beginning of the first year of registration for the relevant programme.

Academic Rule A.4.4.9. is applicable to students whose master's registration had been converted to PhD registration.

### **I.1.11.2 Admission requirements for the qualification**

- Master's degree in Engineering;
- MSc in Engineering Sciences; or
- Another recognized qualification that allows the student to attain equivalent status and which is approved by the Postgraduate Research Quality Assurance Committee.

The School Director may, with notification to the Faculty Management Committee (postgraduate), request students who do not comply with the abovementioned requirements to be provisionally registered for the PhD-degree on the grounds of knowledge and experience gained through prior learning, pending the Recognition of Prior Learning outcome. Refer to I.1.2.1. for the RPL-process to be followed for consideration of non-provisional registration.

### **I.1.11.3 Faculty-specific requirements**

The title of the thesis, the research proposal and the appointment of external examiners must be reviewed by the Faculty Management Committee (postgraduate). Further information regarding rules and procedures are contained in the Faculty-specific rules I.1.2.14., Academic Rules A.5.3.1. and A.5.4., and in the Manual for Postgraduate Study.

In addition to attaining the abovementioned outcomes, students are also required to:

- take part in at least two formal colloquia and/or technical conferences where aspects of their work are presented to an audience of established researchers and peers;
- have at least one full-length research paper on aspects of the thesis submitted for publication in an accredited scientific journal before being allowed to submit the thesis for examination (A.5.4.2.6.);
- have at least one full-length research paper on aspects of the thesis submitted for review in an accredited scientific journal before being allowed to submit the thesis for examination.

Official prescribed forms used in the postgraduate study process are available on the postgraduate e-Fundi site – website: <http://efundi.nwu.ac.za/portal/>.



#### **I.1.11.4 Requirements for a thesis**

Regarding technical requirements, a thesis must comply with all requirements and outcomes laid down by the Faculty. Also see the Manual for Postgraduate Studies and the applicable A-Rules in this regard.

For presenting a thesis in the form of a published research article(s) or (an) unpublished manuscript(s) in article format, see Academic Rule A.5.4.2.7. and the Manual for Postgraduate Studies (3.10).

#### **I.1.11.5 Outcomes**

The programme outcomes have been achieved if the student has made an original contribution to knowledge in a chosen field as evidenced by a thesis with proper structure, style and language that includes:

- Identification and formulation of an original research problem;
- Critical, relevant and comprehensive literature survey indicating the originality of the envisaged contribution;
- Development of the necessary research procedures and experimental facilities/numerical models;
- Execution of either an empirical or numerical investigation to address the research problem;
- Verification and validation of the results;
- Assessment of the results and conclusions making the case for the original contribution.

#### **I.1.11.6 Articulation possibilities**

With the basic and applied expertise and the research skills that the graduate acquires with this qualification in one of the engineering disciplines, the graduate will be empowered, with further learning and research, to pursue other specialized fields at a variety of institutions, both nationally and internationally.

## I.1.11.7

## Programme

DOCTORATES					
Qualification	Programme and Qualification Code	Curriculum Code	Module	Cr	NQF level
Philosophiae Doctor ( <i>PhD</i> )	Chemical Engineering <b>703 104</b>	<b>I901P</b>	CEMI 971	256	10
	Computer Engineering <b>703 113</b>	<b>I910P</b>	EREI 971	256	10
	Computer and Electronic Engineering <b>703 109</b>	<b>I906P</b>	REEI 971	256	10
	Development and Management Engineering <b>703 111</b>	<b>I908P</b>	IIOB 971	256	10
	Electrical Engineering <b>703 105</b>	<b>I902P</b>	EERI 971	256	10
	Electronic Engineering <b>703 106</b>	<b>I903P</b>	EEEI 971	256	10
	Electrical and Electronic Engineering <b>703 108</b>	<b>I905P</b>	ELEI 971	256	10
	Engineering Science <b>703 110</b>	<b>I907P</b>	IWTS 971	256	10
	Mechanical Engineering <b>703 107</b>	<b>I904P</b>	MEGI 971	256	10
	Nuclear Engineering <b>703 112</b>	<b>I909P</b>	NUCI 971	256	10

*\* Note: CRCED Pretoria offers supervision in a variety of the above study areas. Please consult the CRCED personnel at (012) 809 0412.*

## I.2 MODULE OUTCOMES

<b>CEMI 875</b>	<b>NQF level: 9</b>
<b>Title:</b> Fluid-Phase Equilibrium	
<b>Module outcomes:</b> After completion of this module, the student should be able to: <ul style="list-style-type: none"> <li>• use statistical thermodynamics theory for the determination of thermodynamic characteristics of fluids;</li> <li>• establish the thermodynamic equilibrium by means of molecular modelling methods; and</li> <li>• use advanced thermodynamic theory for the development of separation processes such as membrane separation, supercritical extraction and relative distillation.</li> </ul>	
<b>Method of delivery:</b> The module is presented as follows: <ul style="list-style-type: none"> <li>• Approximately 40 hours contact time with the lecturer in the form of formal lectures, tutorials and discussion classes; and</li> <li>• Approximately 120 hours of self-study and preparation of assignments.</li> </ul>	

<b>CEMI 876</b>	<b>NQF level: 9</b>
<b>Title:</b> Separation Processes	
<b>Module outcomes:</b> After completion of this module, the student should be able to: <ul style="list-style-type: none"> <li>• select membrane processes for the separation of fluids as well as for water purification;</li> <li>• develop and model membrane- and membrane processes for mainly fluid separation;</li> <li>• develop and model thermodynamically for mainly petro-chemical substances, supercritical extraction processes; and</li> <li>• develop and model reactive distillation systems for low temperature reactions with homogenous and heterogeneous catalysts.</li> </ul>	
<b>Method of delivery:</b> The module is presented as follows: <ul style="list-style-type: none"> <li>• Approximately 40 hours contact time with the lecturer in the form of formal lectures, tutorials and discussion classes; and</li> <li>• Approximately 120 hours of self-study and preparation of assignments.</li> </ul>	

<b>CEMI 877</b>	<b>NQF level: 9</b>
<b>Title:</b> Coal Technology I	
<b>Module outcomes:</b> After completion of this module, the student should be able to: <ul style="list-style-type: none"> <li>• use coal properties to determine conversion processes such as combustion, gasification and hydrogenation;</li> <li>• quantify the burning and gassing characteristics by means of experimental investigations; and</li> <li>• model fluidized bed combustion and gasification for design purposes.</li> </ul>	
<b>Method of delivery:</b> The module is presented as follows: <ul style="list-style-type: none"> <li>• Approximately 40 hours contact time with the lecturer in the form of formal lectures, tutorials and discussion classes; and</li> <li>• Approximately 120 hours of self-study and preparation of assignments.</li> </ul>	

<b>CEMI 878</b>	<b>NQF level: 9</b>
<b>Title:</b> Coal Technology II	
<b>Module outcomes:</b> After completion of this module, the student should be able to: <ul style="list-style-type: none"> <li>• apply coal properties for beneficiation on coal samples from various mines;</li> <li>• evaluate economic aspects of coal beneficiation;</li> <li>• understand the most important South African coal reserves;</li> <li>• compare and analyse the South African context of coal production in respect of international competition;</li> <li>• describe, evaluate and calculate processes for various separation technologies of international importance; and</li> <li>• undertake research on the relevant problems of coal mining, beneficiation and stockpiling.</li> </ul>	
<b>Method of delivery:</b> The module is presented as follows: <ul style="list-style-type: none"> <li>• Approximately 40 hours contact time with the lecturer in the form of formal lectures, tutorials and discussion classes; and</li> <li>• Approximately 120 hours of self-study and preparation of assignments.</li> </ul>	

<b>CEMI 879</b>	<b>NQF level: 9</b>
<b>Title:</b> Bioreactors and Bioprocess Technology	
<b>Module outcomes:</b> After completion of this module, the student should be able to: <ul style="list-style-type: none"> <li>• define biotechnology and the use of cell culture fermentation biotechnology to make useful products;</li> <li>• understand the principles of bioprocess technology and be knowledgeable about features of various types of bioreactors, bioreactor design and oxygen mass transfer;</li> <li>• describe the selection, preparation and operation of bioreactors and be able to do calculations relevant to bioreactors;</li> <li>• describe the difference between various upstream and downstream processes during bioprocess;</li> <li>• understand and be able to apply the principles of cell and enzyme immobilization and biotransformation;</li> <li>• demonstrate the application of biotechnology in engineering with theoretical and practical aspects.</li> </ul>	
<b>Method of delivery:</b> The module is presented as follows: <ul style="list-style-type: none"> <li>• Approximately 50 hours contact time with the lecturer in the form of formal lectures, tutorials and discussion classes;</li> <li>• Approximately 70 hours contact time with the lecturer in the form of assignments and formal workshops; and</li> <li>• Approximately 40 hours in the form of practical laboratory sessions.</li> </ul>	

<b>CEMI 881</b>	<b>NQF level: 9</b>
<b>Title:</b> Bio-ethanol Process Technology	
<b>Module outcomes:</b> After completion of this module, the student should: <ul style="list-style-type: none"> <li>• have a working knowledge of the cultivation of crops for bio-ethanol production;</li> </ul>	

- have a working knowledge of the enzymes and yeasts used in the production of bio-ethanol;
- know and understand the different production routes for the production of bio-ethanol from a variety of biomass sources;
- have a good understanding of the unit operations involved in the production of bio-ethanol from biomass;
- have a working knowledge of the by-products from a bio-ethanol production plant;
- be able devise a production route for the production of bio-ethanol from different biomass sources;
- have a working knowledge of the standards applicable to bio-ethanol in South Africa;
- know and understand the legislation and strategies that govern bio-ethanol production in South Africa;
- understand the role bio-ethanol plays in South Africa's energy supply chain;
- be conversant with properties of bio-ethanol;
- be able to identify and appreciate barriers of market penetration of bio-ethanol in some developing countries.

**Method of delivery:**

The module is presented as follows:

- Approximately 30 hours contact time with the lecturer in the form of interactive lectures and discussion groups; and
- Approximately 130 hours of self-study.

<b>CEMI 882</b>	<b>NQF level: 9</b>
<b>Title:</b> STS and Renewable Energy	
<b>Module outcomes:</b>	
After completion of this module, the student should:	
<ul style="list-style-type: none"> <li>• understand and know the concepts pertaining to science, technology and society (STS) in context of renewable energy;</li> <li>• be able to describe from an STS viewpoint the basic operation of traditional energy generation technologies;</li> <li>• understand renewable and sustainable energy;</li> <li>• evaluate different technologies with regard to renewability and sustainability;</li> <li>• understand and appreciate the impact of biofuels production on the environment and the society;</li> <li>• understand the balance between social need and technology developments;</li> <li>• understand the socio-economic dynamics involved of biofuels production in rural communities in South Africa;</li> <li>• understand and appreciate the issues surrounding biofuels production and food security.</li> </ul>	
<b>Method of delivery:</b>	
This module is presented over 160 hours as follows:	
<ul style="list-style-type: none"> <li>• Approximately 8 hours contact time with the lecturer in types of formal lectures;</li> <li>• Approximately 30 hours of contact time with the lecturer in a type of formal seminar, where primarily higher order intellectual reasoning skills and topical debates are presented;</li> <li>• Approximately 72 hours of preparation and self-study for the seminars; and</li> <li>• Approximately 50 hours for a community project and meetings.</li> </ul>	

<b>CEMI 883</b>	<b>NQF level: 9</b>
<b>Title:</b> Introduction to Renewable and Sustainable Energy	
<b>Module outcomes:</b> After completion of this module, the student should: <ul style="list-style-type: none"> <li>• have a working knowledge of wind energy;</li> <li>• have a working knowledge of thermal solar energy;</li> <li>• have a working knowledge of photovoltaic solar energy;</li> <li>• have a working knowledge of hydro-energy;</li> <li>• have a working knowledge of geothermal energy;</li> <li>• have a working knowledge of fuel cells;</li> <li>• have a working knowledge of energy storage systems;</li> <li>• have a working knowledge of bio-ethanol processes;</li> <li>• have a working knowledge of biodiesel processes;</li> <li>• have a working knowledge of bio-butanol processes;</li> <li>• know and understand the application field of renewable technologies.</li> </ul>	
<b>Method of delivery:</b> This module is presented as follows: <ul style="list-style-type: none"> <li>• Approximately 20 hours contact time with the lecturer in the form of formal lectures;</li> <li>• Approximately 15 hours of contact time with the lecturer in the form of formal workshops;</li> <li>• Approximately 8 hours contact time with the lecturer in the form of a formal practical demonstration; and</li> <li>• Approximately 117 hours of self-study and preparation of workshops and practical demonstration models.</li> </ul>	

<b>CEMI 884</b>	<b>NQF level: 9</b>
<b>Title:</b> Biodiesel Process Technology	
<b>Module outcomes:</b> After completion of this module, the student should: <ul style="list-style-type: none"> <li>• have a working knowledge of the cultivation of crops for biodiesel production;</li> <li>• be able to devise and/or design an extraction process for the extraction of oil from various oil rich biomass sources;</li> <li>• have a working knowledge of oil refining and polishing steps to prepare oils for the production of biodiesel;</li> <li>• have a working knowledge of the different catalysts used in the esterification reaction;</li> <li>• understand the basic steps in the production of biodiesel;</li> <li>• have a working knowledge of the technologies available for recovery of the catalysts from the esterification reaction mixture;</li> <li>• have a working knowledge of the technologies available for the recovery and purification of glycerol from the biodiesel production process;</li> <li>• be able to devise a production route for the production of biodiesel from various feedstock's;</li> <li>• be able to conduct an economic analysis for a biodiesel production scheme;</li> <li>• have a working knowledge of the standards applicable to biodiesel in South Africa;</li> <li>• know and understand the legislation and strategies that govern biodiesel production in South Africa;</li> <li>• understand the role biodiesel plays in South Africa's energy supply chain;</li> <li>• be conversant with the properties of biodiesel;</li> <li>• be able to identify and appreciate barriers of market penetration of biodiesel fuels in some developing countries.</li> </ul>	

**Method of delivery:**

This module is presented as follows:

- Approximately 30 hours of contact time with the lecturer in the form of interactive lectures and discussion groups; and
- Approximately 130 hours of self-study and preparation of assignments.

<b>EEII 881</b>	<b>NQF level: 9</b>
<b>Title:</b> Data Mining and Knowledge Extraction	
<b>Module outcomes:</b> Motivation for the application of data mining and knowledge extraction, discussion of the typical application and purpose of techniques, requirements for the process of data collection and storing, pre-processing and improvement of data integrity, exploratory searches with regard to patterns in data, distinguishing between various behavioural patterns in data, extraction of rules and/or models which present underlying behaviour, classification of behavioural patterns, cause and effect analysis, prediction of future behaviour, practical examples, complex industrial processes, financial markets, logistics processes, communication networks, client behaviour as part of CRM, and the detection of fraud.	

<b>EEII 882</b>	<b>NQF level: 9</b>
<b>Title:</b> Electrical Power Quality	
<b>Module outcomes:</b> Basis concepts, sources of harmonics and waveform distortion in a power system, effects and symptoms to utility and end-user, mathematical analysis of three-phase non-sinusoidal waveforms, penetration of harmonics in power systems, power theory, power definitions and PQ indices, computer simulations and case studies.	

<b>EEII 883</b>	<b>NQF level: 9</b>
<b>Title:</b> Advanced Protection Systems	
<b>Module outcomes:</b> The module offers the student insight and exposure to the most important types of electrical protection systems, their design, application and behaviour. Basic fault calculations, instrument transformers, overcurrent and earth fault protection, motor, cable, transformer, overhead line and generator protection are focused on. Recent developments in SCADA and ICAP systems are also covered. Students get the opportunity during practical's to test their designs and set-point values on real machines with a variety of relays.	

<b>EEII 884</b>	<b>NQF level: 9</b>
<b>Title:</b> Advanced Signal Processing	
<b>Module outcomes:</b> This module concentrates on digital signal processing methods. Signal processing methods can be classified into two groups, namely transform-oriented and other (e.g. heuristically oriented). The student is introduced to the digitizing process and accuracy of numerical algorithms. Concepts such as vector spaces and orthogonal decomposition of signals are taught, with specific focus on the frequency (Fourier) and time-frequency (wavelet) transforms. Image processing techniques for both the recognition of objects and image enhancement are taught. Fractals, solutions and chaos are discussed from a topological framework.	

<b>EEII 885</b>	<b>NQF level: 9</b>
<b>Title:</b> Information Systems for e-trade and e-logistics	
<b>Module outcomes:</b> The role of e-trade and e-logistics in the modern economy, supporting role of information systems in the operation of e-trade and e-logistics, functional requirements of information systems, automated data collection, transaction processing, store of data, making data available, processing and decision support, architecture of a typical information system for e-trade and e-logistics, international technology standards for information systems, e-trade markets and requirements for successful e-collaboration, interdependency between e-trade markets and logistic planning systems, support of the effectiveness of logistic operations with information systems, decision support and performance management based on business intelligence systems.	

<b>EEII 886</b>	<b>NQF level: 9</b>
<b>Title:</b> Information Security: Strategies and Techniques	
<b>Module outcomes:</b> This module presents the theoretical and practical aspects of information security, from basic principles, risk analysis, to management aspects. On successful completion of the module the student should: <ul style="list-style-type: none"> <li>• be able to identify and apply the principles of information security;</li> <li>• understand and determine information risk;</li> <li>• be able to select appropriate technologies to secure information and understand their limitations;</li> <li>• be able to apply information security; and</li> <li>• know what to do in case of a security breach.</li> </ul>	

<b>EEII 887</b>	<b>NQF level: 9</b>
<b>Title:</b> Kalman Filters	
<b>Module outcomes:</b> This module presents the theoretical aspects of random signal analysis and the minimum-mean-square-error filtering with emphasis on applications. On successful completion of the module the student should: <ul style="list-style-type: none"> <li>• understand the concepts of probability and random variables;</li> <li>• be able to handle the mathematical description of random signals;</li> <li>• be able to calculate the response of linear systems to random inputs;</li> <li>• be able to apply Wiener filtering to stochastic data; and</li> <li>• be able to develop and apply discrete Kalman Filters.</li> </ul>	

<b>EEII 888</b>	<b>NQF level: 9</b>
<b>Title:</b> Power System Dynamics	
<b>Module outcomes:</b> The module introduces students to the dynamic interaction that various power system elements have on each other during transition conditions. The dynamic interaction is described in both electrical and mechanical comparison terms. Specific attention is given to induction motors and synchronous machines and their control systems FACTS elements that can stabilize the power system are investigated and their interactions with other power systems are studied. During practical's, students are offered the opportunity to improve the transition stability of a generator with various control systems.	



<b>EEII 889</b>	<b>NQF level: 9</b>
<b>Title:</b> Compensation of Distortion in Power Systems	
<b>Module outcomes:</b> Basic definitions and characteristics of power quality in power systems. Measurement of power quality phenomena. Analysis of power quality phenomena. Power quality improvement methods. Characteristics of power quality improvement equipment. Design of power quality improvement equipment. Evaluation of power quality improvement equipment. Specification of power quality improvement equipment.	

<b>EEII 891</b>	<b>NQF level: 9</b>
<b>Title:</b> Advanced Electronic Development and Design	
<b>Module outcomes:</b> After the completion of this module, the student must be able to: <ul style="list-style-type: none"> <li>• perform an operational analysis of her/his specific system in order to define a system concept (preliminary development);</li> <li>• perform a functional analysis at preliminary design level (advanced development);</li> <li>• allocate requirements to a system or product (advanced development);</li> <li>• perform a preliminary system synthesis and evaluation;</li> <li>• draw up a development specification for her/his specific system or product; and</li> <li>• draw up design guidelines and constraints (requirements) for detail design.</li> </ul>	

<b>EEII 892</b>	<b>NQF level: 9</b>
<b>Title:</b> Advanced Power Electronics	
<b>Module outcomes:</b> After completion of the module, the student should: <ul style="list-style-type: none"> <li>• be able to demonstrate knowledge and skills pertaining to a wide range of direct current to direct current converters, and be able to design such converters;</li> <li>• have a sound knowledge of the concept of hard and soft switching of transistors;</li> <li>• have a sound knowledge of the design of high frequency magnetic components such as transformers and inductors; and</li> <li>• successful design and implementation of a converter.</li> </ul>	

<b>EEII 893</b>	<b>NQF level: 9</b>
<b>Title:</b> Advanced Electrical Machines	
<b>Module outcomes:</b> After completion of the module, the student should be able to: <ul style="list-style-type: none"> <li>• derive and apply generalized machine comparisons to induction motors and synchronized machines;</li> <li>• design, model and analyse electrical isolation systems of machines;</li> <li>• design, model and analyse the magnetic circuits of machines;</li> <li>• measure, calculate and analyse the factors influencing the performance of machines; and</li> <li>• process and interpret the results of the various statistical monitoring techniques.</li> </ul>	

<b>EERI 877</b>	<b>NQF level: 9</b>
<b>Title:</b> Digital Control Systems	
<b>Module outcomes:</b> Advanced control systems used in typical industrial environments. Aspects covered include	

time-discrete systems and the Z-transform, sample collection and reconstruction, multi-changing systems, open cycle and closed cycle stability, design of controller applications in multi-changing systems, condition changing formulations, minimizing of cost functions, optimal controllers, realizing of digital control systems, system simulation and modern control software.

<b>ERIE 874</b>	<b>NQF level: 9</b>
<b>Title:</b> Neural Networks	
<b>Module outcomes:</b>	
Neural networks find their inspiration in the structure of the human nervous system. Artificial neural networks have a unique advantage above traditional computer programmes in that they have the ability to learn from examples. This advantage makes neural networks suitable to solve various difficult problems. This module focuses on different types of neural networks, the ways in which they can be trained, as well as the application of neural networks on a variety of types of problems.	
<ul style="list-style-type: none"> <li>• <i>Training:</i> Data analysis and visualization, generalization capacity, optimizing, algorithms, error functions.</li> <li>• <i>Topologies:</i> Memory, grouping algorithms and networks, linear networks, multi-layer progress networks, radial base function networks, neural networks with feedback, multi-network systems, fuzzy logic and neural networks.</li> <li>• <i>Application:</i> Pattern recognizing, neural networks in control systems, neural networks and regression.</li> </ul>	

<b>ERIE 875</b>	<b>NQF level: 9</b>
<b>Title:</b> Fuzzy Logic Systems	
<b>Module outcomes:</b>	
Introduction to Fuzzy systems. Description and analysis of fuzzy logic systems. Training of fuzzy logic systems using back-propagation, orthogonal least squares and nearest neighbourhood clustering is discussed. Application of Fuzzy Logic Systems in system identification is an important component of the subject.	

<b>ERIE 876</b>	<b>NQF level: 9</b>
<b>Title:</b> Process Modelling and Identification	
<b>Module outcomes:</b>	
The application of different approaches to process modelling and identification to industrial processes, such as the determination of models from basic physics, with emphasis on bond diagram techniques and fitting of model coefficients by using neural networks. The successful student should be able to write computer code to do modelling from a menu with components.	

<b>IIOB 881</b>	<b>NQF level: 9</b>
<b>Title:</b> Project Management	
<b>Module outcomes:</b>	
After successful completion of the module the student should have knowledge and skills pertaining to the theory, concepts, processes, tools and techniques of project management. He/she will have applied it to a real life study project. The student should further have the capability and confidence to professionally manage projects in the work environment, and he/she should be proficient in the use of project management tools and techniques. Broadly arranged in terms of the following content:	
<ul style="list-style-type: none"> <li>• Project management in perspective;</li> </ul>	

- Project management theory;
- Project management tools;
- Human factors in project management; and
- Risk management factors in project management.

<b>IIOB 882</b>	<b>NQF level: 9</b>
<b>Title:</b> Maintenance Management	
<b>Module outcomes:</b>	
<p>The objective of the module is to teach students the underlying theoretical knowledge and principles of maintenance management in its broadest sense and to equip them with practical know-how of applied maintenance management in industry, thus enabling them to function effectively in this environment.</p> <p>After successful completion of the module the student should have knowledge of:</p> <ul style="list-style-type: none"> <li>• Systems Engineering (SE) principles with emphasis on maintainability and reliability;</li> <li>• the role of maintenance and its management in the SE “bigger picture” with special reference to plant availability;</li> <li>• reliability engineering and general failure mechanisms;</li> <li>• Reliability Centred Maintenance (RCM) and its application in industry;</li> <li>• maintenance theory and its application in today’s high tech environment, including maintenance process re-engineering;</li> <li>• Computerized Maintenance Management Systems (CMMS) and its application;</li> <li>• maintenance information and how to maximize its use;</li> <li>• maintenance life cycle costing and the cost of maintenance; and</li> <li>• maintenance management theory at top academic level and knowledge of its application and management on plant and equipment level.</li> </ul>	

<b>IIOB 883</b>	<b>NQF level: 9</b>
<b>Title:</b> Corporate Career Skills	
<b>Module outcomes:</b>	
<p>The objective of this module is to enhance and accelerate the engineering graduate’s effectiveness and productivity in his employment situation in general, by equipping him with relevant and essential knowledge, skills and values, as these apply to the corporate industrial sector of the economy. After successful completion of the module the student should have knowledge of:</p> <ul style="list-style-type: none"> <li>• the global situation and trends that will and should influence the behaviour of the industrial corporate now and into the future;</li> <li>• the meaning and impact of the global economy;</li> <li>• who the corporate stakeholders are, how they interact and how their interests are and should be balanced;</li> <li>• how the corporate reports to its stakeholders;</li> <li>• how it is held accountable by its stakeholders;</li> <li>• the management structure of the industrial corporate, with associated levels of responsibilities and built-in checks and balances;</li> <li>• the strategic process dictating the direction in which the industrial corporate develops;</li> <li>• key performance areas that drive the success of the industrial corporate;</li> <li>• key risks that may negatively influence the corporate well-being, e.g. HIV/AIDS;</li> <li>• the operational processes that supports the above (budgets, marketing and sales, the supply chain, product development, human resources, environmental and social responsibilities, financial accounting and reporting);</li> <li>• the legal environment within which the corporate operates (the tax system, HR</li> </ul>	

- development legislation, environmental and safety legislation, etc.);
- the physical and psychological impact that the work environment places on staff;
- how these should be managed to cope effectively as an individual and employee; and
- self-insight in how the student fits into all of the above – how to optimize your contribution to your employer, while at the same time developing your career and personal well-being.

<b>IIOB 884</b>	<b>NQF level: 9</b>
<b>Title:</b> Production Optimization Management	
<b>Module outcomes:</b>	
After successful completion of the production optimization management module the student should have demonstrated mastery of basic knowledge and skills pertaining to the theory, concepts, processes, tools and techniques of production optimization.	
Special focus are given to the following methodologies:	
<ul style="list-style-type: none"> <li>Lean manufacturing;</li> <li>Theory of Constraints;</li> <li>Six Sigma; and</li> <li>Material Requirement Planning (MRP).</li> </ul>	
He/she will have applied the abovementioned to a case study.	

<b>IIOB 885</b>	<b>NQF level: 9</b>
<b>Title:</b> Entrepreneurial Career Skills	
<b>Module outcomes:</b>	
After successful completion of the module the student should have knowledge of:	
<ul style="list-style-type: none"> <li>the various legal persons that you can choose from when launching your entrepreneurial career and their attributes;</li> <li>the roles and services offered by various funding institutions and their associated cost structures;</li> <li>your responsibilities towards SARS, and how you should manage these;</li> <li>how to minimize your personal risks and protect your personal assets against business risks;</li> <li>how to manage the two most important business drivers: your marketing drive and your business cash flow; and</li> <li>the business power that cyberspace offers.</li> </ul>	
After successful completion of the module the student should be able (have the skills) to:	
<ul style="list-style-type: none"> <li>pick the winning opportunities and assess their risks and sustainability characteristics;</li> <li>compile your own management accounts and financial statements and deal with other financial and taxation matters;</li> <li>manage a business through liquidation;</li> <li>manage yourself through sequestration and not lose the personal assets you built up during the good times;</li> <li>to start again and to manage the consequences of your previous business failure; and</li> <li>identify, design, capitalize, launch and manage a business.</li> </ul>	
After successful completion of the module the student should understand and appreciate that:	
<ul style="list-style-type: none"> <li>one should have a broader perspective of joys and hardships of entrepreneurial life;</li> <li>one should appreciate that business failure does not mean personal failure; and</li> <li>one will have been coached to face a competitive, tough and unforgiving business world and make a success of your entrepreneurial career.</li> </ul>	

<b>IIOB 886</b>	<b>NQF level: 9</b>
<b>Title:</b> System Engineering	
<b>Module outcomes:</b> After successful completion of the module the student should have knowledge and skills pertaining to the theory, concepts, processes tools and techniques of systems engineering. He/she will have applied it to a real life study project. The student should further have the capability and confidence to use the systems engineering approach to solve problems in the work environment and he/she should be proficient in the use of systems engineering tools and techniques. The module is broadly arranged in terms of the following content:	
<ul style="list-style-type: none"> <li>• Requirement formulation;</li> <li>• System engineering;</li> <li>• Software engineering;</li> <li>• Integrated logistic support;</li> <li>• Acquisition management; and</li> <li>• System management.</li> </ul>	

<b>IIOB 887</b>	<b>NQF level: 9</b>
<b>Title:</b> Quality Management in Engineering Projects	
<b>Module outcomes:</b> The objective of the module is to provide an opportunity for graduate engineers to learn to work in a safety critical project environment with the capability and confidence to contribute appropriate quality management strategies in a multidisciplinary project team. After completion of the module in project quality management the student should be able to demonstrate an understanding and knowledge of the main tenets of the subject in a written and/or verbal discourse in the company of professional peers. The student should:	
<ul style="list-style-type: none"> <li>• demonstrate an understanding of quality as it applies to project management in the context of the quality cycle;</li> <li>• be able to explain project quality management in the context of a safety critical project;</li> <li>• be able to identify the applicable requirements of quality management for a specific safety critical project;</li> <li>• be able to develop a quality management plan applicable to a safety critical project;</li> <li>• be able to identify the required components of quality planning, quality assurance and quality control;</li> <li>• demonstrate interpersonal skills as appropriate to project quality management; and</li> <li>• be able to implement an appreciation of human factors of quality management in a safety critical project.</li> </ul> <p>More specifically, as a summative assessment of learning, the learner should demonstrate skill in the application of the above aspects of project quality management by applying it to a relevant study project and presenting and defending this to a panel of professional peers.</p>	

<b>MEGI 874</b>	<b>NQF level: 9</b>
<b>Title:</b> Computational Fluid Mechanics I	
<b>Module outcomes:</b> This module presents the theoretical and practical aspects of the solution of flow problems encountered in engineering science using Computational Fluid Dynamics (CFD). On successful completion of the module the student should:	
<ul style="list-style-type: none"> <li>• understand the capabilities and limitations of CFD;</li> <li>• be able to generate various types of computational grids;</li> </ul>	

- be able to derive the conservation equations for flow problems and recognize the various formulations for the conservation equations and understand turbulence and the mechanisms which form the basis of various turbulence models;
- understand the various discretization techniques, formulate the finite difference discretization of the Poisson heat equation for various boundary conditions and obtain the numerical solution;
- be able to perform the finite volume discretization of a general conservation equation on an two-dimensional orthogonal grid, assemble the global coefficient matrix understanding the influence of the convective and diffusion terms and apply the boundary values on boundary control volume;
- understand staggered and collocated grids, velocity-pressure decoupling and the SIMPLE (R/C/N) algorithms for the Navier-Stokes equations; and
- be able to generate the computational grid, set up a problem and compute the solution using a commercial code.

<b>MEGI 875</b>	<b>NQF level: 9</b>
<b>Title:</b> Computational Fluid Mechanics II	
<b>Module outcomes:</b>	
The module presents the more advanced theoretical and practical aspects of the solution of flow problems encountered in engineering science using Computational Fluid Dynamics (CFD).	
On successful completion of the module the student should:	
<ul style="list-style-type: none"> <li>• understand the advantages and disadvantages of CFD and its industrial applications;</li> <li>• understand and apply grid transformations;</li> <li>• be able to derive the various transient finite volume discretization, derive the transient coupled velocity-pressure algorithms (SIMPLE and PISO) for incompressible flow on non-orthogonal unstructured grids, understand the finite volume discretization for unstructured non-orthogonal 3D grids, understand higher-order spatial discretization and understand the effect of the various techniques on the convergence and accuracy of solutions;</li> <li>• understand the theory underlying unbound solutions;</li> <li>• be able to recognize various types of models for two-phase flow problems and understand the limitations of the various models; and</li> <li>• understand the solution algorithms for compressible flow problems.</li> </ul>	

<b>MEGI 876</b>	<b>NQF level: 9</b>
<b>Title:</b> Finite Element Methods	
<b>Module outcomes:</b>	
This module presents the theoretical and practical aspects of the solution of second- and fourth-order differential equations encountered in engineering science using the finite element method.	
On successful completion of the module the student should be able to:	
<ul style="list-style-type: none"> <li>• derive the weak formulation and obtain the Galerkin finite element formulation for one- and two-dimensional problems;</li> <li>• discretize the computational domain, compute the contributions from the elements to assemble the global equations, apply the boundary conditions, solve the equations and post-process the results; and</li> <li>• extend the method to solve systems of differential equations, non-linear problems and problems with various constraints.</li> </ul>	

<b>MEGI 877</b>	<b>NQF level: 9</b>
<b>Title:</b> Finite Element Methods for Flow	
<b>Module outcomes:</b>	
This module presents the theoretical and practical aspects of the solution of the Navier-Stokes equations using the finite element method. On successful completion of the module the student should be able to:	
<ul style="list-style-type: none"> <li>• derive the weak formulation and obtain the Galerkin finite element formulation for the Navier-Stokes equations in one and two dimensions;</li> <li>• distinguish between and implement the fully coupled classical velocity-pressure and the penalty function approaches and employ Petrov-Galerkin upwinding;</li> <li>• distinguish between and implement the segregated SIMPLE, SIMPLER and SIMPLEST algorithms; and</li> <li>• extend the method to include non-isothermal flow problems.</li> </ul>	

<b>MEGI 878</b>	<b>NQF level: 9</b>
<b>Title:</b> Energy Management	
<b>Module outcomes:</b>	
Introduction to energy management, overview of energy audit process, energy accounts, economic analysis and life-cycle costs, lighting, refrigeration and air-conditioning, combustion processes and use of industrial waste, steam generation and distribution, control systems, maintenance, insulation, process energy management, alternative energy sources, water management.	

<b>MEGI 879</b>	<b>NQF level: 9</b>
<b>Title:</b> Advanced Engineering Thermodynamics	
<b>Module outcomes:</b>	
<ul style="list-style-type: none"> <li>• Energy and its use in open and closed systems;</li> <li>• Exergy analysis of simple and complex systems;</li> <li>• The time value of money; and</li> <li>• The use of Exergy in thermo-economic analysis.</li> </ul>	

<b>MEGI 884</b>	<b>NQF level: 9</b>
<b>Title:</b> Advanced Strength of Materials	
<b>Module outcomes:</b>	
<ul style="list-style-type: none"> <li>• <i>Linear tension and distortion:</i> Tension transformations, Mohr circle for tension and distortion, tension-distortion of isotropical and orthotropical materials;</li> <li>• <i>Non-elastic material behaviour:</i> Tension distortion behaviour (elastic and plastic), application of load-deflection relationships, failing criteria and safety aspects;</li> <li>• <i>Non-symmetric bending of straight flanges:</i> Maximum tensions, deflections and orientation of the neutral axis under non-symmetrical burden, complete plastic burden under non-symmetrical bend;</li> <li>• <i>Tension concentrations:</i> Neuber nomogram, theoretical tension concentration factors (Shigley), sensitivity;</li> <li>• <i>Fatigue:</i> Design according to Goodman, Gerber and DE elliptical criteria; and</li> <li>• <i>Contact tensions:</i> Analysis of point and line contact tensions.</li> </ul>	

<b>MEGI 889</b>	<b>NQF level: 9</b>
<b>Title:</b> Materials Selection for Design	
<b>Module outcomes:</b> The design process, engineering and its properties, performance and selection indices, materials selection charts, material selection and selection strategies, materials selection – case studies, selection of material and shape, shape – case studies, multiple constraints and compound objectives, case studies: multiple constraints and compound objectives, materials processing and design, case studies: process selection, modern data sources, case-studies: use of data sources, ferrous alloys, non-ferrous alloys, polymers, ceramic composites, materials, aesthetics and industrial design.	

<b>MEGI 894</b>	<b>NQF level: 9</b>
<b>Title:</b> Composite Materials	
<b>Module outcomes:</b> <ul style="list-style-type: none"> <li>• <i>Properties of composite materials:</i> Polymer matrix materials;</li> <li>• <i>Elastic properties of fibre reinforced composite materials:</i> Micromechanical models, laminate analysis, short fibre composites; and</li> <li>• <i>Strength of composite materials:</i> Tensile strength, fibre orientation and tensile properties, tensile properties of multi-layered laminates, compressive strength, shear strength, toughness and fatigue life.</li> </ul>	

<b>MGII 885</b>	<b>NQF level: 9</b>
<b>Title:</b> Thermal-Fluid Systems Modelling I	
<b>Module outcomes:</b> The aim of the module is to present the underlying principles and concepts on which thermal-fluid simulation and design software, such as Flownex, is based. In the process the student should also gain enhanced understanding of the practical implications of the fundamental theoretical principles. This is not a software-user module, but rather an extension and enrichment of the knowledge required to apply modelling and simulation in the design process. In this regard the student will be guided through the development of mathematical models and integrated cycle simulations with the aid of the generic Engineering Equation Solver (EES) software package. Students will be required to successfully complete several thermal-fluid modelling assignments. After completion of this module the student should be able to: <ul style="list-style-type: none"> <li>• integrate comprehensive knowledge of thermodynamics, fluid mechanics and heat transfer with specialized techniques required to simulate thermal-fluid systems for both steady state and transient conditions; and</li> <li>• apply higher level engineering synthesis skills and specialized software tools to create mathematical models with the appropriate degree of complexity that can be used in the simulation and design of thermal-fluid components and systems.</li> </ul>	

<b>MGII 886</b>	<b>NQF level: 9</b>
<b>Title:</b> Thermal-Fluid Systems Modelling II	
<b>Module outcomes:</b> This module builds on the first module (MGII 885) in the series on thermal-fluid system simulation, which addresses the underlying principles and concepts on which simulation and design software are based. Having successfully completed the first module is therefore a pre-requisite to taking part in this one. Also, having applied it extensively in the first module, the student is expected to be quite proficient in the use of the generic Engineering Equation Solver (EES) software package as a simulation tool.	



The focus of this module is on advanced concepts, processes and applications. In the process the student should also gain an enhanced understanding of the practical implications of the fundamental theoretical principles. In this regard the student is expected to develop quite advanced mathematical simulation models of thermal-fluid system components and associated processes.

This is not a software-user module, but rather an extension and enrichment of the knowledge required to apply modelling and simulation in the design process.

After the completion of this module the student must be able to:

- integrate fundamental knowledge of thermodynamics, fluid mechanics and heat transfer with specialized techniques required to simulate advanced thermal-fluid systems and processes; and
- apply higher level engineering synthesis skills and specialized software tools to create mathematical models with the appropriate degree of complexity that can be used in the simulation and design of thermal-fluid components and systems.

<b>MGII 887</b>	<b>NQF level: 9</b>
<b>Title:</b> Gas Turbine Theory and Performance	
<b>Module outcomes:</b>	
<ul style="list-style-type: none"> <li>• <i>Axial compressors:</i> Fundamental concepts regarding axial compressors, general axial flow compressor design, axial compressor stage design principles, velocity triangles, thermodynamic design principles, off-design performance, surge and stall, blade design, mechanical integrity;</li> <li>• <i>Axial turbines:</i> Fundamental concepts of axial flow turbines, thermodynamics of gas turbine process, turbine velocity triangles and turbine blade design; and</li> <li>• <i>Combined gas turbine cycle:</i> Combining of compressor and turbine into a gas turbine cycle, compressor/turbine matching, simulation of gas turbine cycle, transient gas turbine cycle simulations.</li> </ul>	

<b>NUCI 511</b>	<b>NQF level: 8</b>
<b>Title:</b> Nuclear Engineering I	
<b>Module outcomes:</b>	
<p>Students are provided with a broad overview of nuclear power systems to provide them with the basic knowledge they need to function in the nuclear reactor industry. The student should be able to demonstrate an understanding of and the ability to apply and evaluate key terms, concepts, facts, principles, rule and theories of the nuclear field. The student should also have detailed knowledge of the specialization area and how that knowledge relates to other fields. The student's problem solving skills should include the ability to identify, analyse, evaluate, critically reflect on and address complex problems. Therefore, the following topics in nuclear engineering are covered:</p> <p>The history of nuclear engineering, basics of atomic and nuclear physics for engineers, interaction of neutrons and nuclear radiation with matter, basic types of nuclear power plants, neutron diffusion and moderation, nuclear reactor theory, time dependent behaviour and effects and heat generation in nuclear cores.</p>	

<b>NUCI 521</b>	<b>NQF level: 8</b>
<b>Title:</b> Introduction to Thermal-Fluid Sciences	
<b>Module outcomes:</b>	
<ul style="list-style-type: none"> <li>• <i>Thermodynamics:</i> Properties of pure substances, work and heat, First Law of Thermodynamics, Second Law of Thermodynamics, power cycles;</li> <li>• <i>Fluid mechanics:</i> Fluid statics, flow analysis, conservation laws for control volumes,</li> </ul>	

differential forms of basic laws, dimensional analysis, incompressible viscous flow through pipes, one-dimensional compressible flow;

- *Turbo machinery*: Basic laws, compressors, turbines; and
- *Heat transfer*: Conduction, convection and radiation heat transfer, heat exchangers.

**NUCI 571**

**NQF level: 8**

**Title:** Mathematics for Nuclear Engineers

**Module outcomes:**

On the completion of this module the student should be able to solve mathematical problems related to nuclear engineering. With this knowledge he/she should be able to:

- use different methods to solve partial and differential equations analytically;
- study special functions and their application in solving differential equations;
- use this basic knowledge to solve more complex problems; and
- use the methods learnt here in other nuclear engineering modules.

**NUCI 572**

**NQF level: 8**

**Title:** Nuclear Reactor Technology

**Module outcomes:**

The purpose of this module is to introduce students from a non-engineering discipline (BSc or BTech) to nuclear power reactor technology. The module gives a broad overview of the different types of nuclear power reactors, LWR (PWR and BWR), HWR and GCR (AGR and HTR). The module also covers the main technological elements of each type of reactor (fuel elements and core, main components, etc.). Aspects of reactor operation, reactor control and stability are covered, including elementary concepts of reactor fuel and core design, core loading, spent fuel and radioactive waste management.

**NUCI 573**

**NQF level: 8**

**Title:** Nuclear Reactor Safety

**Module outcomes:**

The main purpose of this module is to impart to the student sound knowledge, training and skills in nuclear reactor safety. The main objective is to familiarize the student with the essential principles of nuclear power plant safety, reactor siting, reactor licensing and radiation doses from nuclear power plants, reactor accidents and accident risk analysis, as well as environmental radiation protection requirements. The main areas of nuclear reactor safety cover multiple reactor design to prevent the escape of radioactivity into the environment. This involves the safe design of the fuel, cladding material, the closed coolant system, the reactor vessel and the containment. Reactor control and reactor emergency shutdown systems are presented in the module. The three levels of safety, including suitable site location and essential evacuation procedures in case of an accident, are all an integral part of the module.

**NUCI 574**

**NQF level: 8**

**Title:** Nuclear Engineering Project

**Module outcomes:**

Learners are required demonstrate their ability to execute a project in the field of nuclear engineering independently by publishing a concise scientific report on it.

<b>NUCI 575</b>	<b>NQF level: 8</b>
<b>Title:</b> Nuclear Physics	
<b>Module outcomes:</b>	
Learners are introduced to the principles of radioactivity and the interaction of different types of radiation with matter.	
The content of the module includes:	
<ul style="list-style-type: none"> <li>• Properties of the nucleus;</li> <li>• Basic features of radioactivity and the radioactive decay process;</li> <li>• The radiations emitted by radioactive substances and their interaction with matter;</li> <li>• Comparison of atomic decays; and</li> <li>• Nuclear reactions.</li> </ul>	

<b>NUCI 576</b>	<b>NQF level: 8</b>
<b>Title:</b> Radiation and the Environment	
<b>Module outcomes:</b>	
Learners should develop a sound understanding of the characteristics of ionizing radiation and radio-nuclides, interactions of radiation with matter, biological effects, protection of persons and the environments against harmful effects of radiation and detection and measurement of radiation. The module provides the student with baseline knowledge of the use of radiation and radio-nuclides in various branches of science, technology and medicine, with special emphasis on the monitoring of the environmental pollution on nuclear techniques.	
The content includes:	
<ul style="list-style-type: none"> <li>• Characteristics of ionizing radiation;</li> <li>• Properties of radio-nuclides and other sources of radiation;</li> <li>• Basic processes involved in interactions of radiation with matter;</li> <li>• Main radiation quantities and units;</li> <li>• Physical, chemical and biological effects of radiation;</li> <li>• Protection of people and the environment against harmful effects of radiation;</li> <li>• Radiation detection; measurement and spectrometry;</li> <li>• Monitoring of environmental radioactivity;</li> <li>• Applications of radiation and radio-nuclides in science, industry and medicine; and</li> <li>• The use of nuclear techniques in assessing various pollutants in the environment.</li> </ul>	

<b>NUCI 621</b>	<b>NQF level: 8</b>
<b>Title:</b> Introduction to Thermal-Fluid Sciences	
<b>Module outcomes:</b>	
On the completion of this module the student should be able to:	
<ul style="list-style-type: none"> <li>• demonstrate a thorough understanding of thermodynamics, fluid mechanics, heat transfer and turbo machines by analysing and solving simple and complex industry related problems;</li> <li>• demonstrate an understanding of how the different constituent parts of an integrated system interact and influence each other by describing the interaction and calculating the effect of changing certain variables; and</li> <li>• evaluate the performance of simple and complex systems and propose actions to improve their performance.</li> </ul>	

<b>NUCI 671</b>	<b>NQF level: 8</b>
<b>Title:</b> Mathematics for Nuclear Engineers	
<b>Module outcomes:</b>	
On completion of this module the student should be able to solve mathematical problems related to nuclear engineering. With this knowledge they should be able to:	
<ul style="list-style-type: none"> <li>• use different methods to solve partial and differential equations analytically;</li> <li>• solve partial and differential equations numerically;</li> <li>• study special functions and their application in solving differential equations;</li> <li>• use this basic knowledge to solve more complex problems;</li> <li>• use the methods learnt here in other nuclear engineering modules.</li> </ul>	

<b>NUCI 811</b>	<b>NQF level: 9</b>
<b>Title:</b> Nuclear Engineering I	
<b>Module outcomes:</b>	
The module provides students with a broad overview of nuclear engineering to provide them with the basic knowledge they need to function in the nuclear reactor industry. The student should be able to demonstrate specialist knowledge to enable engagement with criticism of current nuclear research and nuclear practices. The student's problem solving skill should be developed to demonstrate the ability to use a wide range of specialist skills in identifying, conceptualizing, designing and implementing methods to address complex practical and theoretical nuclear problems. The student should also demonstrate an understanding of the consequences of any nuclear solution.	
Therefore, the following topics in nuclear engineering are covered:	
<ul style="list-style-type: none"> <li>• The history of nuclear engineering;</li> <li>• Basics of atomic and nuclear physics for engineers;</li> <li>• Interaction of neutrons and nuclear radiation with matter;</li> <li>• Basic types of nuclear power plants, neutron diffusion and moderation;</li> <li>• Nuclear reactor theory;</li> <li>• Time dependent behaviour and effects;</li> <li>• Heat generation in nuclear cores;</li> <li>• Radiation protection;</li> <li>• Radiation shielding; and</li> <li>• Reactor safety and licencing.</li> </ul>	

<b>NUCI 874</b>	<b>NQF level: 9</b>
<b>Title:</b> Advanced Reactor Analysis I	
<b>Module outcomes:</b>	
The following topics in nuclear engineering are covered:	
<ul style="list-style-type: none"> <li>• Neutron transport theory (<math>S_n</math>, <math>P_n</math> derivation);</li> <li>• Neutron diffusion theory (FD, codes);</li> <li>• Neutron energy distribution;</li> <li>• Neutron thermalization;</li> <li>• Reactivity changes (burn up, point kinetics); and</li> <li>• Introduction to Monte Carlo methods (basic equations, approaches, cross-sections, statistics).</li> </ul>	

<b>NUCI 876</b>	<b>NQF level: 9</b>
<b>Title:</b> High Temperature Gas-Cooled Reactor Thermal-Fluid Analysis	
<b>Module outcomes:</b> Upon completion of this module, students should possess a comprehensive and systematic knowledge base and skills in the following:	
<ul style="list-style-type: none"> <li>• Physical properties of fluids and solid materials used in HTR's;</li> <li>• Pressure drop relationships for flow through a pebble bed reactor;</li> <li>• Heat generation in HTR's;</li> <li>• Heat transfer mechanisms in pebble bed HTR's;</li> <li>• Conservation equations governing heat transfer and fluid flow in HTR's;</li> <li>• Numerical solution techniques of the governing equations; and</li> <li>• HTR design bases.</li> </ul>	

<b>NUCI 877</b>	<b>NQF level: 9</b>
<b>Title:</b> High Temperature Reactor Fuels and Materials	
<b>Module outcomes:</b> On completion of this module, the students are expected to:	
<ul style="list-style-type: none"> <li>• Understand the reasoning for selecting proper materials for HTR's;</li> <li>• Demonstrate knowledge of basic steps of design and fabrication of high temperature reactor fuel;</li> <li>• Calculate main operational parameters such as fuel temperature, burn-up, CO production, etc.;</li> <li>• Discuss main problems and ways of improvements for HTR fuel and structural materials; and</li> <li>• Relate reactor physics, thermal hydraulics and reactor design aspects with reactor fuel and materials.</li> </ul>	

<b>NUCI 878</b>	<b>NQF level: 9</b>
<b>Title:</b> High Temperature Reactor Technology	
<b>Module outcomes:</b> On completion of this module, the student will have obtained a basic knowledge in the field of HTR technology, safety aspects and applications of HTR. The students receive additional information on different processes of electricity production and several of the future important processes of nuclear heat application and on estimation of production costs. The student should be able to analyse physical, technical and safety relevant questions, not only valid for HTR-plants, but for other concepts too.	

<b>NUCI 879</b>	<b>NQF level: 9</b>
<b>Title:</b> Nuclear Project Management	
<b>Module outcomes:</b> After successful completion of the Nuclear Project Management (NPM) module the student should demonstrate mastery of basic knowledge and skills pertaining to the theory, concepts, processes, tools and techniques of project management. He/she will have applied it to a typical nuclear industry project.	

<b>NUCI 882</b>	<b>NQF level: 9</b>
<b>Title:</b> Light Water Reactor Thermal-Hydraulics	
<b>Module outcomes:</b> LWR Thermal-Hydraulics examines detailed thermal hydraulic analysis with an emphasis on those TH phenomena important to Light Water Reactor (LWR) design and operation. Specifically, analysis of the transport equations for single and two-phase flow is presented with an added emphasis on two-phase flow dynamics and heat transfer. Analysis methods for LWR power stations are introduced via the formulation of reactor thermal hydraulic design problems. Particularly, steady state and transient analysis of single, heated channels are covered.	

<b>NUCI 883</b>	<b>NQF level: 9</b>
<b>Title:</b> Nuclear Engineering II	
<b>Module outcomes:</b> On completion of this module, the student will have obtained the basic knowledge in understanding how nuclear power plants are designed and operated. With the knowledge the student have obtained from the module, he/she should be able to solve basic thermal-hydraulic problems related to nuclear reactor engineering and communicate with the engineering community about these problems. The student's knowledge in the thermal-hydraulic analysis of nuclear reactors, as well as knowledge of nuclear fuel and reactor operations, will enable him/her to work in the nuclear industry.	

<b>NUCI 886</b>	<b>NQF level: 9</b>
<b>Title:</b> Pebble Bed Reactor Design	
<b>Module outcomes:</b> Upon completion of this module, learners should possess a comprehensive and systematic knowledge base and skills in the following: <ul style="list-style-type: none"> <li>• Understanding the difference between typical reactors and pebble bed reactors.</li> </ul> Special attention shall be given to: <ul style="list-style-type: none"> <li>• The fuel design;</li> <li>• Reactor design; and</li> <li>• The reactor operation.</li> </ul> The various physical characteristics encountered inside the reactor and how it is simulated by calculation are explained. These properties include aspects of: <ul style="list-style-type: none"> <li>• Neutron moderation;</li> <li>• Double heterogeneity;</li> <li>• Spectrum calculations;</li> <li>• Flux distribution;</li> <li>• Power generation;</li> <li>• Bum-up characteristics;</li> <li>• Pebble movement in the reactor under gravity;</li> <li>• Temperature feedback;</li> <li>• Decay heat production; and</li> <li>• How the characteristics mentioned above and combinations thereof are simulated by the VSOP-A suite of codes.</li> </ul> Students should also be able to independently perform simulations of the design baselines for HTR's using existing codes and interpret the results.	

NUCI 887	NQF level: 9
<b>Title:</b> Reactor Analysis	
<b>Module outcomes:</b>	
<p>Upon successful completion of the module, the student should have acquired basic knowledge of nuclear reactor analysis, which includes the following topics:</p> <ul style="list-style-type: none"> <li>• Physics of neutron-nuclear interactions and fission chain reaction;</li> <li>• Neutron transport model and diffusion theory;</li> <li>• Neutron energy distribution, including slowing down, resonance absorption and group energy method;</li> <li>• Nuclear reactor dynamics; and</li> <li>• Fuel burn-up.</li> </ul> <p>This level of knowledge would enable the student to understand physical principles and apply computational methods for reactor design and analysis such as the calculation of neutron flux distribution in space and energy for simple homogenous geometrics and heterogeneous lattices.</p>	

NUCI 888	NQF level: 9
<b>Title:</b> Reactor Safety	
<b>Module outcomes:</b>	
<p>On completion of this module the student should have developed a basic knowledge in the field of reactor safety. With this knowledge he/she should be able to:</p> <ul style="list-style-type: none"> <li>• understand accidental situations and the student should have learned the necessary methods to evaluate them;</li> <li>• the student should be able to communicate with the engineering community about these problems;</li> <li>• the student should furthermore be able to carry out estimations for important accidents in nuclear plants;</li> <li>• use the basic knowledge to go deeper and to use complex programmes for safety analysis; and</li> <li>• use the knowledge to work in the nuclear industry or in safety organizations for supervision of nuclear power plants.</li> </ul> <p>The methods used in nuclear safety analysis are helpful in other fields of technology.</p>	

NUCI 889	NQF level: 9
<b>Title:</b> Pressurized Water Reactor Technology	
<b>Module outcomes:</b>	
<p>On completion of this module the student should:</p> <ul style="list-style-type: none"> <li>• have basic knowledge to understand how Pressurized Water Reactors (PWR's) are designed and operated;</li> <li>• understand the functions of various PWR systems;</li> <li>• understand how improvements have made this form of power plant the choice for the advanced PWR's now being ordered;</li> <li>• have knowledge of the PWR systems that will help foster an understanding of the various design requirements; and</li> <li>• understand how the various systems interact to provide a reliable and safe source of electricity.</li> </ul>	

File reference: 7P/7.2.5/P-FE