

YEARBOOK 2008

**Faculty of Engineering
Post-graduate**

DEAN: Prof. JIJ Fick

**North-West University
Potchefstroom Campus**

Address all correspondence to:

The Registrar
North-West University, Potchefstroom Campus
Private Bag X6001
POTCHEFSTROOM
2520

Tel: (018) 299-1111/2222

Fax: (018) 299-2799

Internet: <http://www.nwu.ac.za>

YOUR UNIVERSITY NUMBER HAS TO ACCOMPANY ALL CORRESPONDENCE

The General Academic Rules of the University, to which all learners have to subject themselves and which apply to all qualifications offered by the University, appear in a separate publication and are also available on the web page.

Please note:

While taking care to ensure that the information contained in this Year Book is accurate, the Council and Senate of the University do not accept responsibility whatsoever for errors that may occur.

OFFICE BEARERS

DEAN

Prof. J.I.J. Fick, Pr.Eng., M.Sc. Eng. (Met.), (Pret.), Ph.D. (Cranfield)

ADMINISTRATIVE MANAGER: POST-GRADUATE

Mrs. C. Eastes, B.A. (PU for CHE)

SCHOOL DIRECTORS AND MANAGERS: FACULTY OF ENGINEERING

School of Chemical and Minerals Engineering

Prof. F.B. Waanders, Pr.Eng., Pr.Sci.Nat., Ph.D. (PU for CHE)

School of Electrical, Electronic and Computer Engineering

Prof. J.A. de Kock (acting), Pr. Eng., Ph.D., M.Eng., B.Eng.

School of Mechanical Engineering

Prof. CP Storm Ph.D. (Mech Eng) (PU vir CHO)

Post-graduate School of Nuclear Science and Engineering

Director: Prof. G.P. Greyvenstein, Pr.Eng., Ph.D., MBL, M.Eng., B.Eng. (Mechanical)

Centre for Research and Continued Engineering Development [CRCED (Pretoria)]

Manager: Prof. E.H. Mathews, Pr.Eng., Ph.D. (PU for CHE)

Centre for Research and Continued Engineering Development [CRCED (Vaal Triangle)]

Manager: Prof. P.W. Stoker, Pr.Eng., Ph.D. (Engineering) (U.S.)

OTHER

Director: Unit for Energy Systems

Prof. G. van Schoor, Pr.Eng., D.Eng. (RAU)

Director: Separation Science and Technology

Vacant (Enquiries: Prof. Christine Strydom)

FACULTY BOARD

Chairperson: Prof. J.I.J. Fick

Blom, P.W.E. (Prof.)
Bodenstein, C.P. (Prof.)
Campbell, Q.P. (Dr.)
De Kock, J.A. (Prof.)
Du Toit, C.G.de K. (Prof.)
Greyvenstein, G.P. (Prof.)
Helberg, A.S.J. (Prof.)
Holm, J.E.W. (Prof.)
Jordaan, P.W. (Prof.)
Kruger, H.A. (Prof.) (Comp. Sci.)
Markgraaff, J. (Prof.)
Marx, S. (Prof.)
Mathews, E.H. (Prof.) (CRCED* Pretoria)
Spoelstra, J. (Prof.) (Math.)
Stoker, P. (Dr.) (CRCED* Vaal)
Van Schoor, G. (Prof.)
Venter, W.C. (Prof.)
Vosloo, H.C.M. (Prof.) (Chem.)
Waanders, F.B. (Prof.)
Wichers, J.H. (Prof.)
Chairperson of the Engineering Students Society (ISV)

* *CRCED: Centre for Research and Continued Engineering Development*

The above is a list of current board members as at August 2007

Table of Contents

I.1	RULES OF THE FACULTY OF ENGINEERING.....	1
I.1.1.1	INTRODUCTION.....	1
I.1.1.2	Schools, centres and research focus areas.....	1
I.1.1.3	Academic training.....	1
I.1.1.4	Research.....	1
I.1.2	QUALIFICATIONS, PROGRAMMES AND CURRICULA.....	2
I.1.2.1	Qualifications and programmes.....	2
I.1.2.2	Summary of programme qualification- and curriculum codes.....	3
I.1.3	MODULES AND CREDITS.....	4
I.1.3.1	Masters' degree credits.....	4
I.1.3.2	Modules offered: Masters' degrees (M.Eng. and M.Sc.).....	4
I.1.3.3	Philosophiae Doctor (Ph.D.) modules and credits.....	6
I.1.4	TERMINATION OF STUDIES.....	6
I.1.4.1	By the student.....	6
I.1.4.2	By the faculty/university.....	6
I.2	RULES FOR THE DEGREE MASTER OF ENGINEERING (M.ENG.).....	7
I.2.1	ADMISSION AND REGISTRATION.....	7
I.2.1.1	Foreign qualifications.....	7
I.2.2	APPROVAL OF THE STUDY PROGRAMME.....	8
I.2.3	ADDITIONAL REQUIREMENTS.....	8
I.2.4	ASSUMPTIONS REGARDING PRIOR LEARNING.....	8
I.2.5	DURATION OF THE STUDY.....	8
I.2.6	COMPOSITION OF THE M.ENG. PROGRAMME.....	8
I.2.6.1	OPTION A: Comprehensive research-based dissertation.....	9
I.2.6.2	OPTION B: Coursework and research-based or project-based dissertation.....	10
I.2.6.3	Option C: Coursework and project-based mini-dissertation.....	11
I.2.6.4	Requirements for a dissertation or mini-dissertation.....	12
I.2.6.5	Change of Master's study to Doctoral study.....	12
I.2.7	ARTICULATION POSSIBILITIES.....	12
I.2.8	POST-GRADUATE COURSE MODULES.....	13
I.2.8.1	Choice of modules.....	13
I.2.8.2	Course modules from other M.Eng. curricula.....	13

I.2.8.3	Approved list of complementary modules	13
I.2.8.4	Module exemptions	13
I.2.9	EXAMINATION	14
I.2.9.1	Submission of dissertation or mini-dissertation	14
I.2.10	M.ENG. CURRICULA	14
I.2.11	SCHOOL OF CHEMICAL AND MINERALS ENGINEERING	14
I.2.11.1	M.Eng.: Curriculum I871P - Chemical Engineering (Option A)	14
I.2.11.2	M.Eng.: Curriculum I872P - Chemical Engineering (Option B)	14
I.2.11.3	M.Eng.: Curriculum I873P - Chemical Engineering (Option C).....	14
I.2.12	SCHOOL OF ELECTRICAL, ELECTRONIC AND COMPUTER ENGINEERING	15
I.2.12.1	M.Eng.: Curriculum I874P - Electrical Engineering (Option A).....	15
I.2.12.2	M.Eng.: Curriculum I875P - Electrical Engineering (Option B).....	15
I.2.12.3	M.Eng.: Curriculum I877P - Electronic Engineering (Option A)	15
I.2.12.4	M.Eng.: Curriculum I878P - Electronic Engineering (Option B)	15
I.2.12.5	M.Eng.: Curriculum I871P - Computer Engineering (Option A)	15
I.2.12.6	M.Eng.: Curriculum I883P - Electrical & Electronic Engineering (Option A).....	15
I.2.12.7	M.Eng.: Curriculum I884P - Electrical & Electronic Engineering (Option B).....	16
I.2.12.8	M.Eng.: Curriculum I885P - Electrical & Electronic Engineering (Option C).....	16
I.2.12.9	M.Eng.: Curriculum I886P - Computer & Electronic Engineering (Option A).....	16
I.2.12.10	M.Eng.: Curriculum I887P - Computer & Electronic Engineering (Option B).....	17
I.2.12.11	M.Eng.: Curriculum I888P - Computer & Electronic Engineering (Option C).....	17
I.2.13	SCHOOL OF MECHANICAL ENGINEERING	18
I.2.13.1	M.Eng.: Curriculum I880P - Mechanical Engineering (Option A)	18
I.2.13.2	M.Eng.: Curriculum I881P - Mechanical Engineering (Option B)	18
I.2.13.3	M.Eng.: Curriculum I882P - Mechanical Engineering (Option C).....	18
I.2.14	CRCED (VAAL) - DEVELOPMENT AND MANAGEMENT.....	19
I.2.14.1	M.Eng.: Curriculum I891P - Development and Management (Option A).....	19
I.2.14.2	M.Eng.: Curriculum I892P - Development and Management (Option B).....	19
I.2.14.3	M.Eng.: Curriculum I893P - Development and Management (Option C)	19
I.2.15	POST-GRADUATE SCHOOL OF NUCLEAR SCIENCE AND ENGINEERING	20

I.2.15.1	Pre-requisites for entering the M.Eng. in Nuclear Engineering	20
I.2.15.2	M.Eng.: Curriculum I801P - Nuclear Engineering (Option B).....	21
I.2.15.3	M.Eng.: Curriculum I802P - Nuclear Engineering (Option C).....	22

I.3 RULES FOR THE DEGREE OF MASTER OF SCIENCE (M.SC.) IN ENGINEERING SCIENCES23

I.3.1	ADMISSION AND REGISTRATION.....	23
I.3.1.1	Foreign qualifications	23
I.3.2	APPROVAL OF THE STUDY PROGRAMME.....	24
I.3.3	ADDITIONAL REQUIREMENTS.....	24
I.3.4	ASSUMPTIONS REGARDING PRIOR LEARNING.....	24
I.3.5	DURATION OF THE STUDY.....	24
I.3.6	COMPOSITION OF THE M.SC. IN ENGINEERING SCIENCES PROGRAMME.....	24
I.3.6.1	OPTION A: Comprehensive research-based dissertation	25
I.3.6.2	OPTION B: Coursework and research-based or project-based dissertation.....	26
I.3.6.3	Option C: Coursework and project-based mini-dissertation.....	27
I.3.6.4	Requirements for a dissertation or mini-dissertation.....	28
I.3.6.5	Change of Master's study to Doctoral study	28
I.3.7	ARTICULATION POSSIBILITIES	28
I.3.8	POST-GRADUATE COURSE MODULES	29
I.3.8.1	Choice of modules	29
I.3.8.2	Course modules from other M.Sc. in Engineering Sciences curricula	29
I.3.8.3	Approved list of complementary modules	29
I.3.8.4	Module exemptions	29
I.3.9	EXAMINATION.....	30
I.3.9.1	Submission of dissertation or mini-dissertation for examination	30
I.3.10	M.SC. IN ENGINEERING SCIENCES CURRICULA.....	30
I.3.11	SCHOOL OF CHEMICAL AND MINERALS ENGINEERING	30
I.3.11.1	M.Sc.: Curriculum I890P - Chemical Engineering (Option A)	30
I.3.11.2	M.Sc.: Curriculum I891P - Chemical Engineering (Option B)	30
I.3.11.3	M.Sc.: Curriculum I892P - Chemical Engineering (Option C)	30
I.3.12	SCHOOL OF ELECTRICAL, ELECTRONIC AND COMPUTER ENGINEERING.....	31
I.3.12.1	M.Sc.: Curriculum I893P - Electrical & Electronic Engineering (Option A).....	31
I.3.12.2	M.Sc.: Curriculum I894P - Electrical & Electronic Engineering (Option B).....	31

I.3.12.3	M.Sc.: Curriculum I895P - Electrical & Electronic Engineering (Option C).....	31
I.3.12.4	M.Sc.: Curriculum I896P - Computer & Electronic Engineering (Option A).....	32
I.3.12.5	M.Sc.: Curriculum I897P - Computer & Electronic Engineering (Option B).....	32
I.3.12.6	M.Sc.: Curriculum I898P - Computer & Electronic Engineering (Option C).....	32
I.3.13	SCHOOL OF MECHANICAL ENGINEERING	33
I.3.13.1	M.Sc.: Curriculum I887P - Mechanical Engineering (Option A)	33
I.3.13.2	M.Sc.: Curriculum I888P - Mechanical Engineering (Option B)	33
I.3.13.3	M.Sc.: Curriculum I889P - Mechanical Engineering (Option C).....	33
I.3.14	POST-GRADUATE SCHOOL OF NUCLEAR SCIENCE AND ENGINEERING	34
I.3.14.1	Pre-requisites for entering the M.Sc. in Nuclear Engineering	34
I.3.14.2	M.Sc.: Curriculum I801P - Nuclear Engineering (Option B)	35
I.3.14.3	M.Sc.: Curriculum I802P - Nuclear Engineering (Option C).....	36
I.4	RULES FOR THE DEGREE OF PHILOSOPHIAE DOCTOR	37
I.4.1	INTRODUCTION.....	37
I.4.2	ADMISSION AND REGISTRATION.....	37
I.4.2.1	Foreign qualifications	38
I.4.3	APPROVAL OF THE STUDY PROGRAMME.....	38
I.4.4	ADDITIONAL REQUIREMENTS	38
I.4.5	ASSUMPTIONS REGARDING PRIOR LEARNING.....	38
I.4.6	ARTICULATION POSSIBILITIES	39
I.4.7	OUTCOMES	39
I.4.8	DURATION OF THE STUDY	39
I.4.9	EXAMINATION	39
I.4.9.1	Submission of thesis for examination.....	39
I.4.10	PROGRAMMES: PH.D. IN THE FACULTY OF ENGINEERING	40
I.4.11	MODULE DESCRIPTIONS AND/OR OUTCOMES.....	41

I.1 RULES OF THE FACULTY OF ENGINEERING

I.1.1.1 INTRODUCTION

The Faculty rules must be read in conjunction with the General Academic Rules of the University. The General **A-RULES** can be found on the university's web site <http://www.nwu.ac.za>, or consult the Academic Administration department.

Further guidelines and rules regarding post-graduate study are given in the **MANUAL FOR POST-GRADUATE STUDIES**. All students are required to consult this manual in detail. A version of this Manual for Post-graduate Studies is available on the university's web site.

I.1.1.2 Schools, centres and research focus areas

I.1.1.3 Academic training

Post-graduate academic programmes are presented within the faculty of Engineering's four schools and two off-campus centres. Different programmes and programme leaders exist in each school. The schools are responsible for undergraduate and post-graduate academic training of students. The schools are:

- School of Chemical and Minerals Engineering
- School of Electrical, Electronic and Computer Engineering
- School of Mechanical Engineering
- Post-graduate School of Nuclear Science and Engineering

Two Centres for Research and Continued Engineering Development (CRCED's) exist off-campus to cater for needs of post-graduate students mainly in the Vaal Triangle and Gauteng areas.

CRCED Vaal Triangle
CRCED Pretoria

The Masters' course modules are presented and managed by the four schools and CRCED Vaal Triangle. CRCED Pretoria offers supervision for Masters' students in some of the disciplines offered by the faculty. In the coordination and presentation of post-graduate training programmes, the Directors of the Schools are assisted by Post-graduate Programme Managers and by the Post-graduate Administrative Manager.

I.1.1.4 Research

Research in the Faculty of Engineering is managed by two Research Focus Areas:

Unit for Energy Systems
Separation Science and Technology.

The research required for Masters' studies must be conducted in the sub-programmes of the Research Focus Area Unit for Energy Systems or the Focus Areas Separation Science and Technology.

I.1.2

QUALIFICATIONS AND CURRICULA

I.1.2.1

Qualifications

The following qualifications are offered by the faculty:

Qualification	Curriculum
Master of Engineering (M.Eng.)	M.Eng. in Chemical Engineering
	M.Eng. in Electrical Engineering
	M.Eng. in Electronic Engineering
	M.Eng. in Computer Engineering
	M.Eng. in Computer and Electronic Engineering
	M.Eng. in Electrical and Electronic Engineering
	M.Eng. in Mechanical Engineering
	M.Eng. in Nuclear Engineering
	M.Eng. in Development and Management
Master of Science in Engineering Sciences (M.Sc)	M.Sc. in Engineering Sciences (Chemical Engineering)
	M.Sc. in Engineering Sciences (Computer and Electronic Eng.)
	M.Sc. in Engineering Sciences (Electrical and Electronic Eng.)
	M.Sc. in Engineering Sciences (Mechanical Engineering)
	M.Sc. in Engineering Sciences (Nuclear Engineering)
Philosophiae Doctor (Ph.D.)	Ph.D. in Chemical Engineering
	Ph.D. in Computer Engineering
	Ph.D. in Computer and Electronic Engineering
	Ph.D. in Electrical Engineering
	Ph.D. in Electronic Engineering
	Ph.D. in Electrical and Electronic Engineering
	Ph.D. in Mechanical Engineering
	Ph.D. in Development and Management
	Ph.D. in Engineering Science
	Ph.D. in Nuclear Engineering

Study may be undertaken full time or part time in any of the above.

For Honours programmes, see undergraduate yearbook of the faculty of engineering.

I.1.2.2

Summary of qualification- and curriculum codes

M.ENG.	QUALIFICATION CODE	CURRICULUM		
		Option A	Option B	Option C
Chemical Engineering	702110	I871P	I872P	I873P
Computer Engineering	702112	I871P		
Computer & Electronic Eng.	702109		I887P	I888P
Development & Management	702111	I891P	I892P	I893P
Electrical Engineering	702105	I874P		
Electronic Engineering	702106	I877P		
Electrical & Electronic Eng.	702108		I884P	I885P
Mechanical Engineering	702107	I880P	I881P	I882P
Nuclear Engineering	702104		I801P	I802P

M.SC. (Engineering Sciences)	QUALIFICATION CODE	CURRICULUM		
		Option A	Option B	Option C
Chemical Engineering	203152	I890P	I891P	I892P
Computer & Electronic Eng.	203154		I897P	I898P
Electrical & Electronic Eng.	203153		I894P	I895P
Mechanical Engineering	203151	I887P	I888P	I889P
Nuclear Engineering	203200		I801P	I802P

PH.D.	QUALIFICATION CODE	CURRICULUM
Chemical Engineering	703104	I901P
Computer Engineering	703113	I910P
Computer & Electronic Eng.	703109	I906P
Development & Management	703111	I908P
Electrical Engineering	703105	I902P
Electronic Engineering	703106	I903P
Electrical & Electronic Eng.	703108	I905P
Engineering Science	703110	I907P
Mechanical Engineering	703107	I904P
Nuclear Engineering	703112	I909P

I.1.3 MODULES AND CREDITS

I.1.3.1 Masters' degree credits

The total number of credits needed to obtain an M.Eng. or M.Sc. in Engineering Sciences degree is **180 credits**. Each credit represents a nominal 10 hours of study. Students choose one curriculum with certain course modules to be completed in order to obtain the relevant degree.

I.1.3.2 Modules offered: Masters' degrees (M.Eng. and M.Sc.)

The Masters' degree programmes allow for three options, allowing different combinations of coursework and/or dissertations that are either research-based or engineering project-based. While the research-based dissertations provide training in research methodology, the project-based dissertations strive to develop advanced engineering design and/or investigative skills.

The three options can be summarised as follows:

OPTION A		OPTION B		OPTION C	
Description	Ct	Description	Ct	Description	Ct
Dissertation	172	Mini-dissertation	92	Mini-dissertation	44
Research Meth.	8	Research Meth.	8	Research Meth.	8
	180	1 Course module	16	1 Course module	16
		2 Course module	16	2 Course module	16
		3 Course module	16	3 Course module	16
		4 Course module	16	4 Course module	16
		5 Course module	16	5 Course module	16
			180	6 Course module	16
				7 Course module	16
				8 Course module	16
					180

Course modules approved as part of the Masters' degree curricula in the Faculty of Engineering are listed below. Please consult the different curriculum descriptions for more detail. Qualification codes/degree codes for all M.Eng. programmes are also given with each curriculum. For each curriculum, compulsory subjects (where applicable) and elective modules are indicated.

The faculty reserves the right not to offer certain modules during a certain year.

MODULE CODE	MODULE NAME
NVMI 874	Research Methodology
SCHOOL OF CHEMICAL AND MINERALS ENGINEERING	
CEMI 871	Full dissertation (option A)
CEMI 872	Dissertation (option B)
CEMI 875	Fluid-phase equilibrium
CEMI 876	Separation Processes
CEMI 877	Coal Technology I
CEMI 878	Coal Technology II
SCHOOL OF ELECTRICAL, ELECTRONIC AND COMPUTER ENGINEERING	

EERI 871	Full dissertation (option A, Electrical Eng.)
EEEE 871	Full dissertation (option A, Electronic Eng.)
EREI 871	Full dissertation (option A, Computer Eng.)
ELEI 872	Dissertation (option B, Electrical and Electronic Eng.)
ELEI 873	Mini-dissertation (option B, Electrical and Electronic Eng.)
REEI 872	Dissertation (option B, Computer and Electronic Eng.)
REEI 873	Mini-dissertation (option B, Computer and Electronic Eng.)
EEII 881	Data mining and knowledge extraction
EEII 882	Electrical Power Quality
EEII 883	Advanced Protection Systems
EEII 884	Advanced Signal Processing
EEII 885	Information Systems for e-trade and e-logistics
EEII 886	Information Security: Strategies and Techniques
EEII 887	Kalman Filters
EEII 888	Power System Dynamics
EEII 889	The Compensation of Distortion in Power Systems
EEII 891	Advanced electronic development and design
EEII 892	Advanced Power Electronics
EEII 893	Advanced Electrical Machines
EERI 877	Digital Control Systems
ERIE 874	Neural networks
ERIE 875	Fuzzy logic systems
ERIE 876	Process Modelling and Pattern-Recognition
SCHOOL OF MECHANICAL ENGINEERING	
MEGI 874	Computational Fluid Dynamics I
MEGI 875	Computational Fluid Dynamics II
MEGI 876	Finite Element Methods
MEGI 877	Finite Element Methods for Flow
MEGI 878	Energy Management
MEGI 879	Advanced Engineering Thermodynamics
MEGI 884	Advanced Strength of Materials
MEGI 889	Materials Selection for Design
MEGI 894	Composite Materials
MGII 885	Thermal-Fluid Systems Modelling
MGII 887	Gas Turbine Theory and Performance
POST-GRADUATE SCHOOL OF NUCLEAR SCIENCE AND ENGINEERING	
NUCI 511 *	Nuclear Engineering I
NUCI 621	Introduction to Thermal-fluid Sciences
NUCI 671	Mathematics for Nuclear Engineers
NUCI 874	Advanced Reactor Analysis I
NUCI 875	Advanced Reactor Analysis II
NUCI 876	High Temperature Gas-Cooled Reactor Thermal-Fluid Analysis
NUCI 877	High Temperature Reactor Fuels and Materials
NUCI 878	High Temperature Reactor Technology

NUCI879	Nuclear Project Management
NUCI 881	Light Water Reactor Fuels & Materials
NUCI 882	Light Water Reactor Thermal-Hydraulics
NUCI 883	Nuclear Engineering
NUCI 884	Nuclear Fuel Supply & Waste Management
NUCI 885	Nuclear Power Conversion
NUCI 886	Pebble Bed Reactor Design
NUCI 887	Reactor Analysis
NUCI 888	Reactor Safety
FSKN 817	Advanced Nuclear Physics
MEGN 871	Pressurized Water Reactor Technology
CRCED VAAL	
IIOB 881	Project Management
IIOB 882	Maintenance Management
IIOB 883	Corporate Career Skills
IIOB 884	Production Optimisation Management
IIOB 885	Entrepreneurial Career Skills
IIOB 886	System Engineering

* Subject to the approval of the new qualification "Post-graduate Diploma in Nuclear Engineering

I.1.3.3 **Philosophiae Doctor (Ph.D.) modules and credits**

The Ph.D. degree consist of **256 credits**. Students only register for one module, depending on the field of study (see par. I. 4.10).

Students from other universities, or students who have not completed the compulsory module in Research Methodology as part of their Masters' degree study, are also required to take this 8-credit module.

I.1.4 **TERMINATION OF STUDIES**

I.1.4.1 **By the student**

According to general rule A.5.12, notice to cancel registration or terminate studies must be submitted in writing to the University.

I.1.4.2 **By the faculty/university**

A student's registration may be cancelled if he/she fails to comply with the dissertation/thesis proposal submission rules as prescribed (general rule A.13.3). Studies may also be terminated in terms of general rule A.9, i.e. if the student fails to comply with the requirements laid down by the senate and/or faculty, or exceeds the maximum duration of the study period.

A student who does not expect to complete the curriculum within the maximum study period, must, before the end of the maximum allowed period of study, apply to the school director (on the prescribed form), for an extension of the study period for one academic year (in accordance with rule A.13.5.2). The supervisor makes a recommendation to the school director with regard to extension of the study period. Students should contact the faculty post-graduate administrative manager in this regard.

I.2 RULES FOR THE DEGREE MASTER OF ENGINEERING (M.ENG.)

The M.Eng. degree is a degree following on a four-year ECSA accredited Bachelors degree in Engineering. The study may be completed full time or part time.

I.2.1 ADMISSION AND REGISTRATION

The admission and registration requirements are set out in General Rules A.13.1 and A.13.2. Students are also required to have **identified a SUPERVISOR** preferably **BEFORE** applying for admission, and will not be allowed to register unless a supervisor have been confirmed.

Prospective students must first apply for **admission** to the North-West University - forms and information available from the Department of Academic Administration - Post-graduate Admissions - tel. (018) 299-4049.

After a student has been admitted, **registration** forms are issued, which must be signed by the Faculty Post-graduate Administration Manager before the student will be allowed to register. Prescribed **fees** must also be paid **BEFORE** registration.

Students must **re-register** every year according to the prescribed procedure, on or before the date set by the University.

The process can be illustrated as follows:

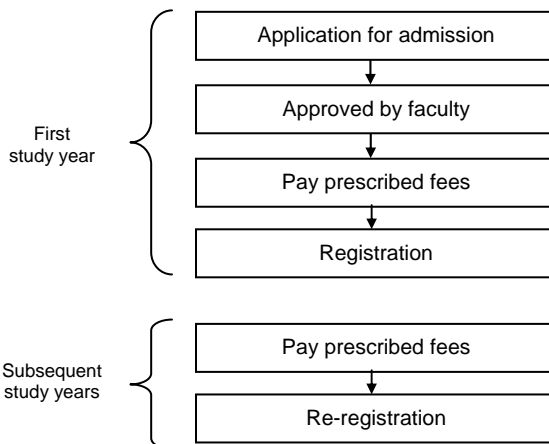

I.2.1.1 Foreign qualifications

Students holding a foreign qualification (i.e. not obtained at a South African University), are required to have the qualification evaluated by SAQA (South African Qualifications Authority) and a certificate re. the evaluation must be submitted with the application form. For more information, contact SAQA at www.saqa.org.za.

I.2.2 APPROVAL OF THE STUDY PROGRAMME

Approval of the study programme is given in terms of the provisions in General Rules A.13.4.2, A.13.4.7 and A.13.4.8 as well as the relevant requirements in the Manual for Post-graduate Studies. **All students must consult this Manual carefully.** This Manual for Post-graduate Studies as well as the General Rules, are available on the university's web site (www.nwu.ac.za).

I.2.3 ADDITIONAL REQUIREMENTS

The title of the dissertation, the research proposal and the appointment of external examiners must be reviewed by the Post-graduate Management Committee. General rule A.13.4.8 also applies. Further information regarding rules and procedures are contained in the general academic rules (A.13.7) and in the Manual for Post-graduate Study.

In addition to attaining the above-mentioned outcomes, students are also required to take part in **at least two formal colloquia and/or technical conferences** where aspects of their work are presented to an audience of peers.

Official **prescribed forms** are used in the post-graduate study process, and are available from the faculty post-graduate admin manager - tel. (018) 299-4020 or are available on the faculty's web site - <http://www.nwu.ac.za>.

I.2.4 ASSUMPTIONS REGARDING PRIOR LEARNING

- (a) The learner holds an applicable four-year bachelors degree in engineering or has been allowed to that status.
- (b) The School Director may, with notification to the faculty post-graduate management committee, allow learners who do not comply with the above-mentioned requirements to register for the M.Sc. or M.Eng. degree, on the grounds of knowledge and experience gained through prior learning. The faculty's policy with regard to Recognition of Prior Learning applies.
- (c) Programme-specific assumptions are, where applicable, indicated at each programme description.

I.2.5 DURATION OF THE STUDY

The minimum term of study is one (1) year and the maximum term of study is two (2) years full-time and three (3) years part-time calculated from the beginning of the first year of registration for the relevant programme.

I.2.6 COMPOSITION OF THE M.ENG. PROGRAMME

The Masters' degree programmes allow for three options. These options allow different combinations of coursework and/or dissertations that are either research-based or engineering project-based. While the research-based dissertations provide training in research methodology, the project-based dissertations strive to develop advanced engineering design and/or investigative skills.

The three options can be summarised as follows:

OPTION A		OPTION B		OPTION C	
<u>Description</u>	<u>Ct</u>	<u>Description</u>	<u>Ct</u>	<u>Description</u>	<u>Ct</u>
Full dissertation	172	Dissertation	92	Mini-dissertation	44
Research Meth.	8	Research Meth.	8	Research Meth.	8
	180	1 Course module	16	1 Course module	16
		2 Course module	16	2 Course module	16
		3 Course module	16	3 Course module	16
		4 Course module	16	4 Course module	16
		5 Course module	16	5 Course module	16
			180	6 Course module	16
				7 Course module	16
				8 Course module	16
					180

I.2.6.1

OPTION A: Comprehensive research-based dissertation

(a) Composition

<u>Description</u>	<u>Credits</u>
Full dissertation	172
Research Methodology	8
	180

(b) Purpose of the programme

To provide thorough training in research methodology.

(c) Programme outcomes

The programme outcomes will have been achieved if it is demonstrated that the candidate is competent in applying research methodology as evidenced by a dissertation with proper structure, style and language that includes:

- Identification of the research problem and formulation of clear objectives for the study.
- A critical, relevant and comprehensive literature survey.
- Development of the necessary research procedures and experimental facilities/numerical models.
- Execution of either an empirical or numerical investigation in order to address the research problem.
- Verification and validation of the results.
- Assessment of the results.
- Conclusions, generalisations and recommendations.

I.2.6.2

OPTION B: Coursework and research-based or project-based dissertation

(a) Composition

<u>Description</u>	<u>Credits</u>
Dissertation	92
Research Methodology	8
Elective course module (1)	16
Elective course module (2)	16
Elective course module (3)	16
Elective course module (4)	16
Elective course module (5)	16
Total credits:	180

Note: At least three (3) of the five (5) 16-credit modules must be engineering technology courses, within the chosen curriculum.

(b) Purpose of the programme

To provide specialist knowledge in a chosen field and competence in research methodology or advanced design and/or investigative skills.

(c) Programme outcomes

The programme outcomes will have been achieved if it is demonstrated that:

- The candidate is competent in applying specialised knowledge in a chosen field as evidenced by coursework assessment that includes:
 - Application of specialised tools and techniques.
 - Higher level problem solving and engineering synthesis.
 - Integration of knowledge across fields.

- The candidate is competent in applying research methodology or advanced design and/or investigative skills as evidenced by a dissertation with proper structure, style and language that includes:
 - Identification of the research or engineering problem and formulation of clear objectives for the study.
 - A critical and relevant literature survey.
 - Development of the necessary research or design/ investigative procedures and experimental facilities/ numerical models.
 - Execution of a comprehensive design or investigation to address the problem.
 - Verification of the results
 - Assessment of the results
 - Conclusions

I.2.6.3

Option C: Coursework and project-based mini-dissertation

(a) Composition

Description	Credits
Mini-dissertation	44
Research Methodology	8
Elective course module (1)	16
Elective course module (2)	16
Elective course module (3)	16
Elective course module (4)	16
Elective course module (5)	16
Elective course module (6)	16
Elective course module (7)	16
Elective course module (8)	16
Total credits:	180

Note: At least four (4) of the eight (8) 16-credit modules must be engineering technology courses, within the chosen curriculum.

(b) Purpose of the programme

To provide specialist knowledge in a chosen field and competence in advanced design and/or investigative skills.

(c) Programme outcomes

The programme outcomes will have been achieved if it is demonstrated that:

- The candidate is competent in applying specialised knowledge in a chosen field as evidenced by coursework assessment that includes:
 - Application of specialised tools and techniques.
 - Higher level problem solving and engineering synthesis.
 - Integration of knowledge across fields.
- The candidate has attained advanced design or investigative skills as evidenced by a project-based mini-dissertation with proper structure, style and language that includes:
 - Identification of the engineering problem and formulation of clear objectives for the study.
 - A clear description of the background to the problem.
 - Execution of a comprehensive design or investigation to address the problem.
 - Presentation and assessment of the proposed solution.
 - Conclusions.

I.2.6.4 Requirements for a dissertation or mini-dissertation

General rule A.13.7 stipulates that a dissertation or mini-dissertation must produce proof that the learner is familiar with the method of research. Regarding technical requirements, a dissertation or mini-dissertation must comply with all requirements and outcomes laid down by the faculty. Also see the **Manual for Post-graduate Studies** in this regard.

For presenting a dissertation or mini-dissertation in the form of a published research article(s) or (an) unpublished manuscript(s) in article format, see general rule A.13.7.3.

I.2.6.5 Change of Master's study to Doctoral study

General rule A.13.8 stipulates that a learner who is registered for a masters' degree and who, according to the unanimous opinion of the study leader, the Research Director and the School Director concerned, has reached outcomes, of which the quality and extent which are acceptable for a doctorate, may apply to the Faculty Board to change the registration for the masters' degree to registration for the doctorate. A learner for whom such concession has been granted:

- (a) must complete the examination paper portion of the master's examination (where applicable) successfully before the thesis may be submitted;
- (b) must comply with all rules and prescriptions laid down by the University in connection with a doctorate; and
- (c) may not receive the doctorate until at least the number of credits has been acquired and the period of time has elapsed since acquisition of the qualification which allowed admission to the master's degree in terms of the appropriate faculty rules prescribed for a doctorate.

I.2.7 ARTICULATION POSSIBILITIES

- (a) After the successful completion of the M.Eng. programme, graduates who have performed adequately may be allowed to continue with a doctoral programme in the core module/programme in which the qualification has been awarded.
- (b) Credit will be given to modules passed at other faculties or universities, provided the outcome and total credit requirements for this qualification/programme will be fully complied with.
- (c) The expertise that the graduate acquires with this qualification in one of the engineering disciplines will empower him / her to continue with further learning and research in various other specialised fields in a variety of institutions.

I.2.8 POST-GRADUATE COURSE MODULES

I.2.8.1 Choice of modules

Note that for **Option A** curricula, there is in each case only a compulsory module for the dissertation plus research methodology. Option A students may also register for any of the elective modules offered, for non-degree purposes.

For **Option B** curricula, there is in each case a compulsory module for the mini-dissertation plus research methodology, plus a list of elective courses from which five (5) must be chosen. Other compulsory modules are, where applicable, indicated at each curriculum.

For **Option C** curricula, there is in each case a compulsory module for the mini-dissertation/research report plus research methodology, plus a list of elective courses from which eight (8) must be chosen. Other compulsory modules are, where applicable, indicated at each curriculum.

I.2.8.2 Course modules from other M.Eng. curricula

Any post-graduate course module in any school in the faculty of Engineering may be chosen after consultation with the appropriate programme manager and his/her supervisor, provided that:

- (a) More than 50% of course modules are within the chosen curriculum.
- (b) The remaining course modules are chosen from the list of approved modules in the other M.Eng. curricula, or from the approved list of complementary subjects, as listed in I.2.8.3 below.
- (c) The supervisor has given permission in writing for the choice of other course modules to be taken.

I.2.8.3 Approved list of complementary modules

Complementary modules offered by the Potchefstroom Business School as part of their MBA course, that can be taken by post-graduate engineering students are the following:

MCTP 824	Management of Information (<i>second semester</i>)
MDTP 825	Operations Management (<i>second semester</i>)

Please note that students need to attend the above lectures from the start of the course. Enquiries should be addressed to the MBA Programme Manager, at tel. (018) 299 1415.

I.2.8.4 Module exemptions

According to general rule A.5.7, a student who joins this University after having completed only a portion of or a full qualification at another institution of higher learning may, with a view to further study at this University, apply in writing for recognition of modules, provided that exemption shall not be granted for more than half of the number of modules required for the curriculum. The student may repeat modules from which he/she cannot be exempted.

Any registered student of this University who wishes to change a curriculum in the course of his/her study period may, with a view to further study at this University, must apply in writing to the appropriate faculty for recognition of any modules which he/she has already passed and which forms part of the curriculum to which the learner wishes to change.

I.2.9 EXAMINATION

The examination for the Masters' degree is conducted in accordance with the requirements of General Rule A.13.6. 16-credit course modules should preferably be completed in the first year of study.

I.2.9.1 Submission of dissertation or mini-dissertation for examination

According to general rule A.13.9, a dissertation or mini-dissertation must be submitted for examination before or on the date determined annually by the senate and indicated in the relevant annual timetable. Certain prescribed forms are to be completed before and at submission. Please consult the Faculty's Post-graduate Administration Manager for the necessary procedures to be followed and forms to be completed.

I.2.10 M.ENG. CURRICULA

Although the research are managed by either the Unit for Energy Systems or RFA Separation Science and Technology, the course modules are managed by the respective schools. Curricula are listed under the schools or units in which they are presented, for easy reference. **Note:** CRCED Pretoria offers supervision in a variety of the available study areas. Please consult the CRCED personnel at (012) 809-0653.

I.2.11 SCHOOL OF CHEMICAL AND MINERALS ENGINEERING

Enquiries with regard to these curricula to be directed to the Director: School of Chemical and Minerals Engineering at tel. (018) 299-1656.

I.2.11.1 M.Eng.: Curriculum I871P - Chemical Engineering (Option A)

Qualification code: 702110

Type	Code	Description	Credits
Compulsory Modules	CEMI 871	Full Dissertation	172
	NVMI 874	Research Methodology	8
Total credits to be obtained:			180

I.2.11.2 M.Eng.: Curriculum I872P - Chemical Engineering (Option B)

Qualification code: 702110

Type	Code	Description	Credits
Compulsory	CEMI 873	Dissertation	92
	NVMI 874	Research Methodology	8
Elective modules	CEMI 875	Fluid-phase Equilibrium	16
	CEMI 876	Separation Processes	16
	CEMI 877	Coal Technology I	16
	CEMI 878	Coal Technology II	16
	Please select 1 (one) 16-credit module from any of the other M.Eng. curricula (discuss with supervisor)		16
Total credits to be obtained:			180

I.2.11.3 M.Eng.: Curriculum I873P - Chemical Engineering (Option C)

This curriculum is currently being modified and will not be available for enrolment in 2008.

I.2.12 SCHOOL OF ELECTRICAL, ELECTRONIC AND COMPUTER ENGINEERING

Enquiries with regard to these curricula to be directed to the Director: School of Electrical, Electronic and Computer Engineering at tel. (018) 299-1978.

I.2.12.1 M.Eng.: Curriculum I874P - Electrical Engineering (Option A)

Qualification code: 702105

Type	Code	Description	Credits
Compulsory Modules	EERI 871	Full Dissertation	172
	NVMI 874	Research Methodology	8
Total credits to be obtained:			180

I.2.12.2 M.Eng.: Curriculum I875P - Electrical Engineering (Option B)

No new applications for this curriculum are accepted from 2008, since this curriculum is being phased out.

I.2.12.3 M.Eng.: Curriculum I877P - Electronic Engineering (Option A)

Qualification code: 702106

Type	Code	Description	Credits
Compulsory Modules	EEEE 871	Full Dissertation	172
	NVMI 874	Research Methodology	8
Total credits to be obtained:			180

I.2.12.4 M.Eng.: Curriculum I878P - Electronic Engineering (Option B)

No new applications for this curriculum are accepted from 2008, since this curriculum is being phased out.

I.2.12.5 M.Eng.: Curriculum I871P - Computer Engineering (Option A)

Qualification code: 702112

Type	Code	Description	Credits
Compulsory Modules	EREI 871	Full Dissertation	172
	NVMI 874	Research Methodology	8
Total credits to be obtained:			180

I.2.12.6 M.Eng.: Curriculum I883P - Electrical & Electronic Engineering (Option A)

No new applications for this curriculum are accepted from 2007, since this curriculum is being phased out.

I.2.12.7

M.Eng.: Curriculum I884P - Electrical & Electronic Engineering (Option B)

Qualification code: 702108

Type	Code	Description	Credits
Compulsory	ELEI 872	Dissertation	92
	NVMI 874	Research Methodology	8
Elective modules [choose five (5)]	EEII 882	Electrical Power Quality	16
	EEII 883	Advanced Protection Systems	16
	EEII 884	Advanced Signal Processing	16
	EEII 887	Kalman Filters	16
	EEII 888	Power System Dynamics	16
	EEII 889	The Compensation of Distortion in Power Systems	16
	EEII 891	Advanced electronic development and design	16
	EEII 892	Advanced Power Electronics	16
	EEII 893	Advanced Electrical Machines	16
	EERI 877	Digital Control Systems	16
	ERIE 874	Neural networks	16
	ERIE 875	Fuzzy logic systems	16
	ERIE 876	Process Modelling and Pattern-Recognition	16
Total credits to be obtained:			180

I.2.12.8

M.Eng.: Curriculum I885P - Electrical & Electronic Engineering (Option C)

Qualification code: 702108

Type	Code	Description	Credits
Compulsory	ELEI 873	Mini-dissertation	44
	NVMI 874	Research Methodology	8
Elective modules [choose eight (8)]	EEII 882	Electrical Power Quality	16
	EEII 883	Advanced Protection Systems	16
	EEII 884	Advanced Signal Processing	16
	EEII 887	Kalman Filters	16
	EEII 888	Power System Dynamics	16
	EEII 889	The Compensation of Distortion in Power Systems	16
	EEII 891	Advanced electronic development and design	16
	EEII 892	Advanced Power Electronics	16
	EEII 893	Advanced Electrical Machines	16
	EERI 877	Digital Control Systems	16
	ERIE 874	Neural networks	16
	ERIE 875	Fuzzy logic systems	16
	ERIE 876	Process Modelling and Pattern-Recognition	16
Total credits to be obtained:			180

I.2.12.9

M.Eng.: Curriculum I886P - Computer & Electronic Engineering (Option A)

No new applications for this curriculum are accepted from 2008, since this curriculum is being phased out.

I.2.12.10 M.Eng.: Curriculum I887P - Computer & Electronic Engineering (Option B)

Qualification code: 702109

Type	Code	Description	Credits
Compulsory	REEI 872	Dissertation	92
	NVMI 874	Research Methodology	8
Elective modules [choose five (5)]	EEII 881	Data mining and knowledge extraction	16
	EEII 884	Advanced Signal Processing	16
	EEII 885	Information Systems for e-trade and e-logistics	16
	EEII 886	Information Security: Strategies and Techniques	16
	EEII 887	Kalman Filters	16
	EEII 891	Advanced electronic development and design	16
	EEERI 877	Digital Control Systems	16
	ERIE 874	Neural networks	16
	ERIE 875	Fuzzy logic systems	16
	ERIE 876	Process Modelling and Pattern-Recognition	16
Total credits to be obtained:			180

I.2.12.11 M.Eng.: Curriculum I888P - Computer & Electronic Engineering (Option C)

Qualification code: 702109

Type	Code	Description	Credits
Compulsory	REEI 873	Mini-dissertation	44
	NVMI 874	Research Methodology	8
Elective modules [choose eight (8)]	EEII 881	Data mining and knowledge extraction	16
	EEII 884	Advanced Signal Processing	16
	EEII 885	Information Systems for e-trade and e-logistics	16
	EEII 886	Information Security: Strategies and Techniques	16
	EEII 887	Kalman Filters	16
	EEERI 877	Digital Control Systems	16
	ERIE 874	Neural networks	16
	ERIE 875	Fuzzy logic systems	16
	ERIE 876	Process Modelling and Pattern-Recognition	16
	EEII 891	Advanced electronic development and design	16
Total credits to be obtained:			180

I.2.13 SCHOOL OF MECHANICAL ENGINEERING

Enquiries with regard to these curricula to be directed to the Director: School of Mechanical Engineering at tel. (018) 299-1316.

I.2.13.1 M.Eng.: Curriculum I880P - Mechanical Engineering (Option A)

Qualification code: 702107

Type	Code	Description	Credits
Compulsory Modules	MEGI 871	Full Dissertation	172
	NVMI 874	Research Methodology	8
Total credits to be obtained:			180

I.2.13.2 M.Eng.: Curriculum I881P - Mechanical Engineering (Option B)

Qualification code: 702107

Type	Code	Description	Credits
Compulsory	MEGI 872	Dissertation	92
	NVMI 874	Research Methodology	8
Elective modules [choose five (5)]	MEGI 874	Computational Fluid Dynamics I	16
	MEGI 875	Computational Fluid Dynamics II	16
	MEGI 876	Finite Element Methods	16
	MEGI 877	Finite Element Methods for Flow	16
	MEGI 878	Energy Management	16
	MEGI 879	Advanced Engineering Thermodynamics	16
	MEGI 884	Advanced Strength of Materials	16
	MEGI 889	Materials Selection for Design	16
	MEGI 894	Composite Materials	16
	MGII 885	Thermal-Fluid Systems Modelling	16
	MGII 887	Gas Turbine Theory and Performance	16
Total credits to be obtained:			180

I.2.13.3 M.Eng.: Curriculum I882P - Mechanical Engineering (Option C)

Qualification code: 702107

Type	Code	Description	Credits
Compulsory	MEGI 873	Mini-dissertation	44
	NVMI 874	Research Methodology	8
Elective modules [choose eight (8)]	MEGI 874	Computational Fluid Dynamics I	16
	MEGI 875	Computational Fluid Dynamics II	16
	MEGI 876	Finite Element Methods	16
	MEGI 877	Finite Element Methods for Flow	16
	MEGI 878	Energy Management	16
	MEGI 879	Advanced Engineering Thermodynamics	16
	MEGI 884	Advanced Strength of Materials	16
	MEGI 889	Materials Selection for Design	16
	MEGI 894	Composite Materials	16
	MGII 885	Thermal-Fluid Systems Modelling	16
	MGII 887	Gas Turbine Theory and Performance	16
Total credits to be obtained:			180

I.2.14 CRCED (VAAL) - DEVELOPMENT AND MANAGEMENT

The following curricula in Development and Management are offered by the Centre for Research and Continued Engineering Development - CRCED (Vaal) and lectures are presented on a part-time basis, on the Vaal Triangle Campus. Enquiries to be directed to the programme leader, prof. PW Stoker, at tel. (016) 981-3951.

I.2.14.1 M.Eng.: Curriculum I891P - Development and Management (Option A)

Qualification code: 702111

Type	Code	Description	Credits
Compulsory Modules	IIOB 871	Full Dissertation	172
	NVMI 874	Research Methodology	8
Total credits to be obtained:			180

I.2.14.2 M.Eng.: Curriculum I892P - Development and Management (Option B)

Qualification code: 702111

Type	Code	Description	Credits
Compulsory	IIOB 872	Dissertation	92
	NVMI 874	Research Methodology	8
Elective modules [choose five (5)]	IIOB 881	Project Management	16
	IIOB 882	Maintenance Management	16
	IIOB 883	Corporate Career Skills	16
	IIOB 884	Production Optimisation Management	16
	IIOB 885	Entrepreneurial Career Skills	16
	IIOB 886	System Engineering	16
	MCTP 824	Management of Information	16
	MDTP 825	Operations Management	16
Total credits to be obtained:			180

I.2.14.3 M.Eng.: Curriculum I893P - Development and Management (Option C)

Qualification code: 702111

Type	Code	Description	Credits
Compulsory	IIOB 873	Mini-dissertation	44
	NVMI 874	Research Methodology	8
Elective modules [choose eight (8)]	IIOB 881	Project Management	16
	IIOB 882	Maintenance Management	16
	IIOB 883	Corporate Career Skills	16
	IIOB 884	Production Optimisation Management	16
	IIOB 885	Entrepreneurial Career Skills	16
	IIOB 886	System Engineering	16
	MCTP 824	Management of Information	16
	MDTP 825	Operations Management	16
Total credits to be obtained:			180

I.2.15

POST-GRADUATE SCHOOL OF NUCLEAR SCIENCE AND ENGINEERING

Please note that the Nuclear Engineering courses are presented on a distance-contact model. More information regarding the course schedule, lecture venue, structure of the courses etc. can be obtained from the Post-graduate School of Nuclear Science and Engineering, at tel. (018) 299-1355. The option A (full dissertation) curriculum is not offered for Nuclear Engineering.

I.2.15.1

Pre-requisites for entering the M.Eng. in Nuclear Engineering

Students must have passed a B.Sc. Hons / B.Eng. degree to be approved..

The route to entering the Masters' programme can be described as follows:

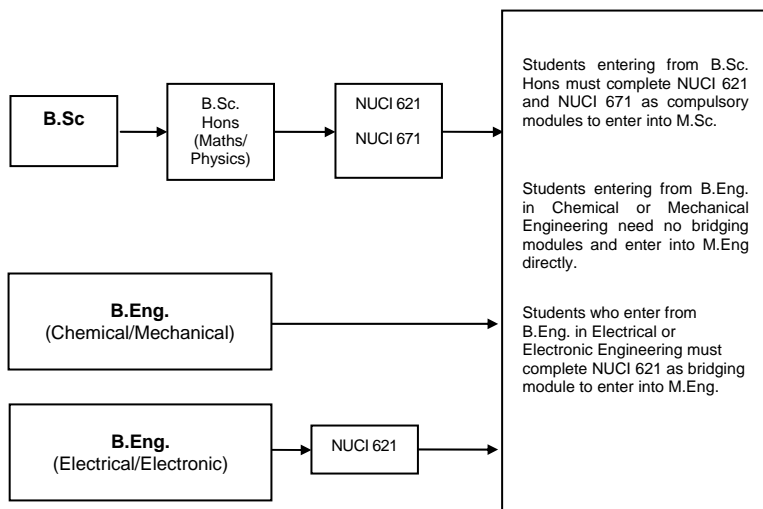

/

I.2.15.2

M.Eng.: Curriculum I801P - Nuclear Engineering (Option B)

Qualification code: 702104

Type	Code	Module	Cr	Pre-requisite
Compulsory	NUCI 872	Dissertation	92	-
	NVMI 874	Research Methodology	8	-
	NUCI 511	Nuclear Engineering I	16	-
	NUCI 883	Nuclear Engineering	16	NUCI 511* NUCI 621* NUCI 671*
	NUCI 887	Reactor Analysis	16	NUCI 883
Elective modules [choose two (2)]	NUCI 888	Reactor Safety	16	NUCI 883, NUCI 887
	NUCI 874	Advanced Reactor Analysis I	16	NUCI 887
	NUCI 875	Advanced Reactor Analysis II	16	NUCI 874
	NUCI 876	High Temperature Gas-Cooled Reactor Thermal-Fluid Analysis	16	NUCI 883, MEGI 874**
	NUCI 877	High Temperature Reactor Fuels and Materials	16	NUCI 883, NUCI 887
	NUCI 878	High Temperature Reactor Technology	16	NUCI 883, NUCI 887
	NUCI 886	Pebble Bed Reactor Design	16	NUCI 883, NUCI 874
	NUCI 879	Nuclear Project Management	16	
	MEGN 871	Pressurized Water Reactor Technology	16	NUCI 883, NUCI 887
	MGII 885	Thermal-Fluid systems Modelling	16	NUCI 621*
	MGII 887	Gas Turbine Theory and Performance	16	NUCI 621*
Total credits to be obtained:			180	

** Note: MEGI 874 is part of the M.Eng in Mechanical Engineering curriculum (I881P / I882P). Students are allowed to take this module as part of the Nuclear Engineering curriculum (see par. I.2.8.2).

The following modules will be offered from 2009 only:

Code	Module	Cr	Pre-requisite
NUCI 884	Nuclear Fuel Supply & Waste Management	16	NUCI 883, NUCI 887
NUCI 881	Light Water Reactor Fuels & Materials	16	NUCI 883
NUCI 882	Light Water Reactor Thermal-Hydraulics	16	NUCI 883
NUCI 885	Nuclear Power Conversion	16	NUCI 883
FSKN 817	Advanced Nuclear Physics	16	To be confirmed

I.2.15.3

M.Eng.: Curriculum I802P - Nuclear Engineering (Option C)

Qualification code: 702104

Type	Code	Module	Cr	Pre-requisite
Compulsory	NUCI 873	Dissertation	44	-
	NVMI 874	Research Methodology	8	-
	NUCI 511	Nuclear Engineering I	16	-
	NUCI 883	Nuclear Engineering	16	NUCI 511* NUCI 621* NUCI 671*
	NUCI 887	Reactor Analysis	16	NUCI 883
	NUCI 888	Reactor Safety	16	NUCI 883, NUCI 887
Elective modules [choose four (4)]	NUCI 874	Advanced Reactor Analysis I	16	NUCI 887
	NUCI 875	Advanced Reactor Analysis II	16	NUCI 874
	NUCI 876	High Temperature Gas-Cooled Reactor Thermal-Fluid Analysis	16	NUCI 883, MEGI 874**
	NUCI 877	High Temperature Reactor Fuels and Materials	16	NUCI 883, NUCI 887
	NUCI 878	High Temperature Reactor Technology	16	NUCI 883, NUCI 887
	NUCI 886	Pebble Bed Reactor Design	16	NUCI 883, NUCI 874
	NUCI 879	NuclearProject Management	16	
	MEGN 871	Pressurized Water Reactor Technology	16	NUCI 883, NUCI 887
	MGII 885	Thermal-Fluid systems Modelling	16	NUCI 621*
	MGII 887	Gas Turbine Theory and Performance	16	NUCI 621*
Total credits to be obtained:			180	

** Note: MEGI 874 is part of the M.Eng in Mechanical Engineering curriculum (I881P / I882P). Students are allowed to take this module as part of the Nuclear Engineering curriculum (see par. I.2.8.2)

The following modules will be offered from 2009 only:

Code	Module	Cr	Pre-requisite
NUCI 884	Nuclear Fuel Supply & Waste Management	16	NUCI 883, NUCI 887
NUCI 881	Light Water Reactor Fuels & Materials	16	NUCI 883
NUCI 882	Light Water Reactor Thermal-Hydraulics	16	NUCI 883
NUCI 885	Nuclear Power Conversion	16	NUCI 883
FSKN 817	Advanced Nuclear Physics	16	To be confirmed

I.3 RULES FOR THE DEGREE OF MASTER OF SCIENCE (M.SC.) IN ENGINEERING SCIENCES

The M.Sc.-degree in Engineering Science may follow on a B.Sc. (Hons.) degree or a four-year degree of Bachelor in Engineering or another recognized qualification that will allow the learner to attain equivalent status and which is approved by the Post-graduate Research Quality Assurance Committee. The study may be completed full time or part time.

I.3.1 ADMISSION AND REGISTRATION

The admission and registration requirements are set out in General Rules A.13.1 and A.13.2. Students are also required to have **identified a SUPERVISOR** preferably **BEFORE** applying for admission, and will not be allowed to register unless a supervisor have been confirmed.

Prospective students must first apply for **admission** to the North-West University - forms and information available from the Department of Academic Administration - Post-graduate Admissions - tel. (018) 299-4049.

After a student has been admitted, **registration** forms are issued, which must be signed by the Faculty Post-graduate Administration Manager before the student will be allowed to register. Prescribed **fees** must also be paid **BEFORE** registration.

Students must **re-register** every year according to the prescribed procedure, on or before the date set by the University. The process can be illustrated as follows:

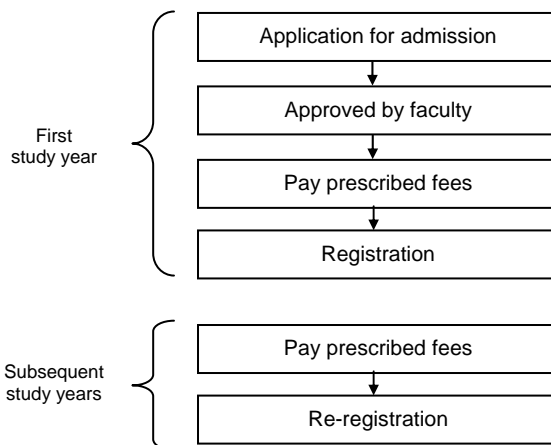

I.3.1.1 Foreign qualifications

Students holding a foreign qualification (i.e. not obtained at a South African University), are required to have the qualification evaluated by SAQA (South African Qualifications Authority) and a certificate re. the evaluation must be submitted with the application form. Visit the website at www.saqa.org.za.

I.3.2 APPROVAL OF THE STUDY PROGRAMME

Approval of the study programme is given in terms of the provisions in General Rules A.13.4.2, A.13.4.7 and A.13.4.8 as well as the relevant requirements in the Manual for Post-graduate Studies. **All students must consult this Manual carefully.** This Manual for Post-graduate Studies as well as the General Rules, are available on the university's web site (www.nwu.ac.za).

I.3.3 ADDITIONAL REQUIREMENTS

The title of the dissertation, the research proposal and the appointment of external examiners must be reviewed by the Post-graduate Management Committee. General rule A.13.4.8 also applies. Further information regarding rules and procedures are contained in the general academic rules (A.13.7) and in the Manual for Post-graduate Study.

In addition to attaining the above-mentioned outcomes, students are also required to take part in **at least two formal colloquia and/or technical conferences** where aspects of their work are presented to an audience of peers.

Official **prescribed forms** are used in the post-graduate study process, and are available from the faculty post-graduate admin manager - tel. (018) 299-4020 or are available on the faculty's web site - <http://www.nwu.ac.za>.

I.3.4 ASSUMPTIONS REGARDING PRIOR LEARNING

- (a) The learner holds an applicable Honours B.Sc. degree and/or an applicable four-year Bachelors degree, or has been allowed to that status.
- (b) The School Director may, with notification to the faculty post-graduate management committee, allow learners who do not comply with the above-mentioned requirements to register for the M.Sc. degree, on the grounds of knowledge and experience gained through prior learning. The faculty's policy with regard to Recognition of Prior Learning applies.
- (c) Programme-specific assumptions are, where applicable, indicated at each programme description.

I.3.5 DURATION OF THE STUDY

The minimum term of study is one (1) year and the maximum term of study is two (2) years full-time and three (3) years part-time calculated from the first year of registration for the relevant programme.

I.3.6 COMPOSITION OF THE M.SC. IN ENGINEERING SCIENCES PROGRAMME

The Masters' degree programmes allow for three options. These options allow different combinations of coursework and/or dissertations that are either research-based or engineering project-based. While the research-based dissertations provide training in research methodology, the project-based dissertations strive to develop advanced engineering design and/or investigative skills.

The three options can be summarised as follows:

OPTION A		OPTION B		OPTION C	
<u>Description</u>	<u>Ct</u>	<u>Description</u>	<u>Ct</u>	<u>Description</u>	<u>Ct</u>
Dissertation	172	Mini-dissertation	92	Mini-dissertation	44
Research Meth.	8	Research Meth.	8	Research Meth.	8
	<hr/>	1 Course module	16	1 Course module	16
	180	2 Course module	16	2 Course module	16
		3 Course module	16	3 Course module	16
		4 Course module	16	4 Course module	16
		5 Course module	16	5 Course module	16
			<hr/>	6 Course module	16
			180	7 Course module	16
				8 Course module	16
					<hr/>
					180

I.3.6.1

OPTION A: Comprehensive research-based dissertation

(a) Composition

<u>Description</u>	<u>Credits</u>
Full dissertation	172
Research Methodology	8
	<hr/>
	180

(b) Purpose of the programme

To provide thorough training in research methodology.

(c) Programme outcomes

The programme outcomes will have been achieved if it is demonstrated that the candidate is competent in applying research methodology as evidenced by a dissertation with proper structure, style and language that includes:

- Identification of the research problem and formulation of clear objectives for the study.
- A critical, relevant and comprehensive literature survey.
- Development of the necessary research procedures and experimental facilities/numerical models.
- Execution of either an empirical or numerical investigation in order to address the research problem.
- Verification and validation of the results.
- Assessment of the results.
- Conclusions, generalisations and recommendations.

I.3.6.2

OPTION B: Coursework and research-based or project-based dissertation**(a) Composition**

<u>Description</u>	<u>Credits</u>
Dissertation	92
Research Methodology	8
Elective course module (1)	16
Elective course module (2)	16
Elective course module (3)	16
Elective course module (4)	16
Elective course module (5)	16
Total credits:	180

Note: At least three (3) of the five (5) 16-credit modules must be engineering technology courses, within the chosen curriculum.

(b) Purpose of the programme

To provide specialist knowledge in a chosen field and competence in research methodology or advanced design and/or investigative skills.

(c) Programme outcomes

The programme outcomes will have been achieved if it is demonstrated that:

- The candidate is competent in applying specialised knowledge in a chosen field as evidenced by coursework assessment that includes:
 - Application of specialised tools and techniques.
 - Higher level problem solving and engineering synthesis.
 - Integration of knowledge across fields.
- The candidate is competent in applying research methodology or advanced design and/or investigative skills as evidenced by a dissertation with proper structure, style and language that includes:
 - Identification of the research or engineering problem and formulation of clear objectives for the study.
 - A critical and relevant literature survey.
 - Development of the necessary research or design/ investigative procedures and experimental facilities/ numerical models.
 - Execution of a comprehensive design or investigation to address the problem.
 - Verification of the results
 - Assessment of the results
 - Conclusions

I.3.6.3

Option C: Coursework and project-based mini-dissertation

(a) Composition

Description	Credits
Project-based mini-dissertation	44
Research Methodology	8
Elective course module (1)	16
Elective course module (2)	16
Elective course module (3)	16
Elective course module (4)	16
Elective course module (5)	16
Elective course module (6)	16
Elective course module (7)	16
Elective course module (8)	16
Total credits:	180

Note: At least four (4) of the eight (8) 16-credit modules must be engineering technology courses, within the chosen curriculum.

(b) Purpose of the programme

To provide specialist knowledge in a chosen field and competence in advanced design and/or investigative skills.

(c) Programme outcomes

The programme outcomes will have been achieved if it is demonstrated that:

- The candidate is competent in applying specialised knowledge in a chosen field as evidenced by coursework assessment that includes:
 - Application of specialised tools and techniques.
 - Higher level problem solving and engineering synthesis.
 - Integration of knowledge across fields.
- The candidate has attained advanced design or investigative skills as evidenced by a project-based mini-dissertation with proper structure, style and language that includes:
 - Identification of the engineering problem and formulation of clear objectives for the study.
 - A clear description of the background to the problem.
 - Execution of a comprehensive design or investigation to address the problem.
 - Presentation and assessment of the proposed solution.
 - Conclusions.

I.3.6.4 Requirements for a dissertation or mini-dissertation

General rule *A.13.7* stipulates that a dissertation or mini-dissertation must produce proof that the learner is familiar with the method of research. Regarding technical requirements, a dissertation or mini-dissertation must comply with all requirements and outcomes laid down by the faculty. Also see the **Manual for Post-graduate Studies** in this regard.

For presenting a dissertation or mini-dissertation in the form of a published research article(s) or (an) unpublished manuscript(s) in article format, see general rule *A.13.7.3*.

I.3.6.5 Change of Master's study to Doctoral study

General Rule *A.13.8* stipulates that a learner who is registered for a masters' degree and who, according to the unanimous opinion of the study leader, the Research Director and the School Director concerned, has reached outcomes, of which the quality and extent which are acceptable for a doctorate, may apply to the Faculty Board to change the registration for the masters' degree to registration for the doctorate. A learner for whom such concession has been granted:

- (a) must complete the examination paper portion of the master's examination (where applicable) successfully before the thesis may be submitted;
- (b) must comply with all rules and prescriptions laid down by the University in connection with a doctorate; and
- (c) may not receive the doctorate until at least the number of credits has been acquired and the period of time has elapsed since acquisition of the qualification which allowed admission to the master's degree in terms of the appropriate faculty rules prescribed for a doctorate.

I.3.7 ARTICULATION POSSIBILITIES

- (a) After the successful completion of the M.Sc. programme, graduates who have performed adequately may be allowed to continue with a doctoral programme in the core module/programme in which the qualification has been awarded.
- (b) Credit will be given to modules passed at other faculties or universities, provided the outcome and total credit requirements for this qualification/programme will be fully complied with.
- (c) The expertise that the graduate acquires with this qualification in one of the engineering disciplines will empower him / her to continue with further learning and research in various other specialised fields in a variety of institutions.

I.3.8 POST-GRADUATE COURSE MODULES

I.3.8.1 Choice of modules

Note that for **Option A** curricula, there is in each case only a compulsory module for the dissertation plus research methodology. Option A students may also register for any of the elective modules offered, for non-degree purposes.

For **Option B** curricula, there is in each case a compulsory module for the mini-dissertation plus research methodology, plus a list of elective courses from which five (5) must be chosen. Other compulsory modules are, where applicable, indicated at each curriculum.

For **Option C** curricula, there is in each case a compulsory module for the mini-dissertation/research report plus research methodology, plus a list of elective courses from which eight (8) must be chosen. Other compulsory modules are, where applicable, indicated at each curriculum.

I.3.8.2 Course modules from other M.Sc. in Engineering Sciences curricula

Any post-graduate course module in any school in the faculty of Engineering may be chosen after consultation with the appropriate programme manager and his/her supervisor, provided that:

- (a) More than 50% of course modules are within the chosen curriculum.
- (b) The remaining course modules are chosen from the list of approved modules in the other M.Eng. curricula, or from the approved list of complementary subjects, as listed in I.3.8.3 below.
- (c) The supervisor has given permission in writing for the choice of other course modules to be taken.

I.3.8.3 Approved list of complementary modules

Complementary modules offered by the Potchefstroom Business School as part of their MBA course, that can be taken by post-graduate engineering students are the following:

MCTP 824	Management of Information (<i>second semester</i>)
MDTP 825	Operations Management (<i>second semester</i>)

Please note that students need to attend the above lectures from the start of the course. Enquiries should be addressed to the MBA Programme Manager, at tel. (018) 299 1415.

I.3.8.4 Module exemptions

According to general rule A.5.7, a student who joins this University after having completed only a portion of or a full qualification at another institution of higher learning may, with a view to further study at this University, apply in writing for recognition of modules, provided that exemption shall not be granted for more than half of the number of modules required for the curriculum. The student may repeat modules from which he/she cannot be exempted.

Any registered student of this University who wishes to change a curriculum in the course of his/her study period may, with a view to further study at this University, must apply in writing to the appropriate faculty for recognition of any modules which he/she has already passed and which forms part of the curriculum to which the learner wishes to change.

I.3.9 EXAMINATION

The examination for the Masters' degree is conducted in accordance with the requirements of General Rule A.13.6. 16-credit course modules should preferably be completed in the first year of study.

I.3.9.1 Submission of dissertation or mini-dissertation for examination

According to general rule A.13.9, a dissertation or mini-dissertation must be submitted for examination before or on the date determined annually by the senate and indicated in the relevant annual timetable. Certain prescribed forms are to be completed before and at submission. Please consult the Faculty's Post-graduate Administration Manager for the necessary procedures to be followed and forms to be completed.

I.3.10 M.SC. IN ENGINEERING SCIENCES CURRICULA

Although the research are managed by either the Unit for Energy Systems or RFA Separation Science and Technology, the course modules are managed by the respective schools. Curricula are listed under the schools or units in which they are presented, for easy reference.

I.3.11 SCHOOL OF CHEMICAL AND MINERALS ENGINEERING

Enquiries with regard to these curricula to be directed to the Director: School of Chemical and Minerals Engineering at tel. (018) 299-1656.

I.3.11.1 M.Sc.: Curriculum I890P - Chemical Engineering (Option A)

Qualification code: 203152

Type	Code	Description	Credits
Compulsory Modules	CEMI 871	Dissertation	172
	NVMI 874	Research Methodology	8
Total credits to be obtained:			180

I.3.11.2 M.Sc.: Curriculum I891P - Chemical Engineering (Option B)

Qualification code: 203152

Type	Code	Description	Credits
Compulsory	CEMI 873	Dissertation	92
	NVMI 874	Research Methodology	8
Elective modules	CEMI 875	Fluid-phase Equilibrium	16
	CEMI 876	Separation Processes	16
	CEMI 877	Coal Technology I	16
	CEMI 878	Coal Technology II	16
	Please select 1 (one) 16-credit module from any of the other M.Eng. curricula (discuss with supervisor)		16
Total credits to be obtained:			180

I.3.11.3 M.Sc.: Curriculum I892P - Chemical Engineering (Option C)

This curriculum is currently being modified and will not be available for enrolment in 2008.

I.3.12 SCHOOL OF ELECTRICAL, ELECTRONIC AND COMPUTER ENGINEERING

Enquiries with regard to these curricula to be directed to the Director: School of Electrical, Electronic and Computer Engineering at tel. (018) 299-1978.

I.3.12.1 M.Sc.: Curriculum I893P - Electrical & Electronic Engineering (Option A)

No new applications for this curriculum are accepted from 2007, since this curriculum is being phased out.

I.3.12.2 M.Sc.: Curriculum I894P - Electrical & Electronic Engineering (Option B)

Qualification code: 203153

Type	Code	Description	Credits
Compulsory	ELEI 872	Dissertation	92
	NVMI 874	Research Methodology	8
Elective modules [choose five (5)]	EEII 882	Electrical Power Quality	16
	EEII 883	Advanced Protection Systems	16
	EEII 884	Advanced Signal Processing	16
	EEII 887	Kalman Filters	16
	EEII 888	Power System Dynamics	16
	EEII 889	The Compensation of Distortion in Power Systems	16
	EEII 891	Advanced electronic development & design	16
	EEII 892	Advanced Power Electronics	16
	EEII 893	Advanced Electrical Machines	16
	EERI 877	Digital Control Systems	16
	ERIE 874	Neural networks	16
	ERIE 875	Fuzzy logic systems	16
	ERIE 876	Process Modelling and Pattern-Recognition	16
Total credits to be obtained:			180

I.3.12.3 M.Sc.: Curriculum I895P - Electrical & Electronic Engineering (Option C)

Qualification code: 203153

Type	Code	Description	Credits
Compulsory	ELEI 873	Mini-dissertation	44
	NVMI 874	Research Methodology	8
Elective modules [choose eight (8)]	EEII 882	Electrical Power Quality	16
	EEII 883	Advanced Protection Systems	16
	EEII 884	Advanced Signal Processing	16
	EEII 887	Kalman Filters	16
	EEII 888	Power System Dynamics	16
	EEII 889	The Compensation of Distortion in Power Systems	16
	EEII 891	Advanced electronic development & design	16
	EEII 892	Advanced Power Electronics	16
	EEII 893	Advanced Electrical Machines	16
	EERI 877	Digital Control Systems	16
	ERIE 874	Neural networks	16
	ERIE 875	Fuzzy logic systems	16
	ERIE 876	Process Modelling and Pattern-Recognition	16
Total credits to be obtained:			180

I.3.12.4 M.Sc.: Curriculum I896P - Computer & Electronic Engineering (Option A)

No new applications for this curriculum are accepted from 2007, since this curriculum is being phased out.

I.3.12.5 M.Sc.: Curriculum I897P - Computer & Electronic Engineering (Option B)

Qualification code: 203154

Type	Code	Description	Credits
Compulsory	REEI 872	Dissertation	92
	NVMI 874	Research Methodology	8
Elective modules [choose five (5)]	EEII 881	Data mining and knowledge extraction	16
	EEII 884	Advanced Signal Processing	16
	EEII 885	Information Systems for e-trade and e-logistics	16
	EEII 886	Information Security: Strategies and Techniques	16
	EEII 887	Kalman Filters	16
	EEII 891	Advanced electronic development and design	16
	EERI 877	Digital Control Systems	16
	ERIE 874	Neural networks	16
	ERIE 875	Fuzzy logic systems	16
	ERIE 876	Process Modelling and Pattern-Recognition	16
Total credits to be obtained:			180

I.3.12.6 M.Sc.: Curriculum I898P - Computer & Electronic Engineering (Option C)

Qualification code: 203154

Type	Code	Description	Credits
Compulsory	REEI 873	Mini-dissertation	44
	NVMI 874	Research Methodology	8
Elective modules [choose eight (8)]	EEII 881	Data mining and knowledge extraction	16
	EEII 884	Advanced Signal Processing	16
	EEII 885	Information Systems for e-trade and e-logistics	16
	EEII 886	Information Security: Strategies and Techniques	16
	EEII 887	Kalman Filters	16
	EEII 891	Advanced electronic development and design	16
	EERI 877	Digital Control Systems	16
	ERIE 874	Neural networks	16
	ERIE 875	Fuzzy logic systems	16
	ERIE 876	Process Modelling and Pattern-Recognition	16
Total credits to be obtained:			180

I.3.13 SCHOOL OF MECHANICAL ENGINEERING

Enquiries with regard to these curricula to be directed to the Director: School of Mechanical Engineering at tel. (018) 299-1316.

I.3.13.1 M.Sc.: Curriculum I887P - Mechanical Engineering (Option A)

Qualification code: 203151

Type	Code	Description	Credits
Compulsory Modules	MEGI 871	Full Dissertation	172
	NVMI 874	Research Methodology	8
Total credits to be obtained:			180

I.3.13.2 M.Sc.: Curriculum I888P - Mechanical Engineering (Option B)

Qualification code: 203151

Type	Code	Description	Credits
Compulsory	MEGI 872	Dissertation	92
	NVMI 874	Research Methodology	8
Elective modules [choose five (5)]	MEGI 874	Computational Fluid Dynamics I	16
	MEGI 875	Computational Fluid Dynamics II	16
	MEGI 876	Finite Element Methods	16
	MEGI 877	Finite Element Methods for Flow	16
	MEGI 878	Energy Management	16
	MEGI 879	Advanced Engineering Thermodynamics	16
	MEGI 884	Advanced Strength of Materials	16
	MEGI 889	Materials Selection for Design	16
	MEGI 894	Composite Materials	16
	MGII 885	Thermal-Fluid Systems Modelling	16
	MGII 887	Gas Turbine Theory and Performance	16
Total credits to be obtained:			180

I.3.13.3 M.Sc.: Curriculum I889P - Mechanical Engineering (Option C)

Qualification code: 203151

Type	Code	Description	Credits
Compulsory	MEGI 873	Mini-dissertation	44
	NVMI 874	Research Methodology	8
Elective modules [choose eight (8)]	MEGI 874	Computational Fluid Mechanics I	16
	MEGI 875	Computational Fluid Mechanics II	16
	MEGI 876	Finite Element Methods	16
	MEGI 877	Finite Element Methods for Flow	16
	MEGI 878	Energy Management	16
	MEGI 879	Advanced Engineering Thermodynamics	16
	MEGI 884	Advanced Strength of Materials	16
	MEGI 889	Materials Selection for Design	16
	MEGI 894	Composite Materials	16
	MGII 885	Thermal-Fluid Systems Modelling	16
	MGII 887	Gas Turbine Theory and Performance	16
Total credits to be obtained:			180

I.3.14

POST-GRADUATE SCHOOL OF NUCLEAR SCIENCE AND ENGINEERING

Please note that the Nuclear Engineering courses are presented on a distance-contact model. More information regarding the course schedule, lecture venue, structure of the courses etc. can be obtained from the Post-graduate School of Nuclear Science and Engineering, at tel. (018) 299-1355. The option A curriculum is not offered for Nuclear Engineering.

I.3.14.1

Pre-requisites for entering the M.Sc. in Nuclear Engineering

The route to entering the Masters' programme can be described as follows:

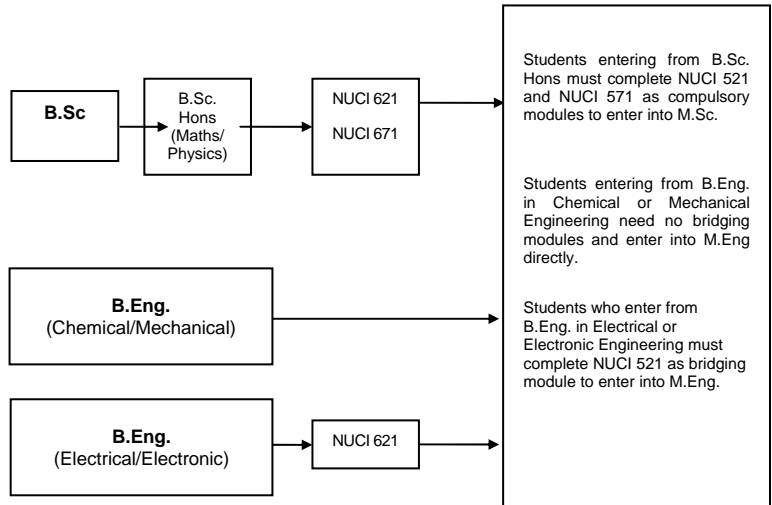

I.3.14.2

M.Sc.: Curriculum I801P - Nuclear Engineering (Option B)

Qualification code: 203200

Type	Code	Module	Cr	Pre-requisite
Compulsory	NUCI 872	Dissertation	92	-
	NVMI 874	Research Methodology	8	-
	NUCI 511	Nuclear Engineering I	16	-
	NUCI 883	Nuclear Engineering	16	NUCI 511* NUCI 621* NUCI 671*
	NUCI 887	Reactor Analysis	16	NUCI 883
Elective modules [choose two (2)]	NUCI 888	Reactor Safety	16	NUCI 883, NUCI 887
	NUCI 874	Advanced Reactor Analysis I	16	NUCI 887
	NUCI 875	Advanced Reactor Analysis II	16	NUCI 874
	NUCI 876	High Temperature Gas-Cooled Reactor Thermal-Fluid Analysis	16	NUCI 883, MEGI 874**
	NUCI 877	High Temperature Reactor Fuels and Materials	16	NUCI 883, NUCI 887
	NUCI 878	High Temperature Reactor Technology	16	NUCI 883, NUCI 887
	NUCI 886	Pebble Bed Reactor Design	16	NUCI 883, NUCI 874
	NUCI 879	Nuclear Project Management	16	
	MEGN 871	Pressurized Water Reactor Technology	16	NUCI 883, NUCI 887
	MGII 885	Thermal-Fluid systems Modelling	16	NUCI 621*
MGII 887	Gas Turbine Theory and Performance	16	NUCI 621*	
Total credits to be obtained:			180	

** Note: MEGI 874 is part of the M.Sc. in Engineering Sciences (Mechanical Engineering) curriculum (I888P / I889P). Students are allowed to take this module as part of the Nuclear Engineering curriculum (see par. I.2.8.2)

The following modules will be offered from 2009 only:

Code	Module	Cr	Pre-requisite
NUCI 884	Nuclear Fuel Supply & Waste Management	16	NUCI 883, NUCI 887
NUCI 881	Light Water Reactor Fuels & Materials	16	NUCI 883
NUCI 882	Light Water Reactor Thermal-Hydraulics	16	NUCI 883
NUCI 885	Nuclear Power Conversion	16	NUCI 883
FSKN 817	Advanced Nuclear Physics	16	To be confirmed

I.3.14.3

M.Sc.: Curriculum I802P - Nuclear Engineering (Option C)

Qualification code: 203200

Type	Code	Module	Cr	Pre-requisite
Compulsory	NUCI 873	Dissertation	44	-
	NVMI 874	Research Methodology	8	-
	NUCI 511	Nuclear Engineering I	16	-
	NUCI 883	Nuclear Engineering	16	NUCI511*, NUCI621*, NUCI671*
	NUCI 887	Reactor Analysis	16	NUCI 883
	NUCI 888	Reactor Safety	16	NUCI 883, NUCI 887
Elective modules [choose four (4)]	NUCI 874	Advanced Reactor Analysis I	16	NUCI 887
	NUCI 875	Advanced Reactor Analysis II	16	NUCI 874
	NUCI 876	High Temperature Gas-Cooled Reactor Thermal-Fluid Analysis	16	NUCI 883, MEGI 874*
	NUCI 877	High Temperature Reactor Fuels and Materials	16	NUCI 883, NUCI 887
	NUCI 878	High Temperature Reactor Technology	16	NUCI 883, NUCI 887
	NUCI 886	Pebble Bed Reactor Design	16	NUCI 883, NUCI 874
	NUCI 879	Nuclear Project Management	16	
	MEGN 871	Pressurized Water Reactor Technology	16	NUCI 883, NUCI 887
	MGII 885	Thermal-Fluid systems Modelling	16	NUCI 621*
MGII 887	Gas Turbine Theory and Performance	16	NUCI 621*	
Total credits to be obtained:			180	

** Note: MEGI 874 is part of the M.Sc. in Engineering Sciences (Mechanical Engineering) curriculum (I888P / I889P). Students are allowed to take this module as part of the Nuclear Engineering curriculum (see par. I.2.8.2)

The following modules will be offered from 2009 only:

Code	Module	Cr	Pre-requisite
NUCI 884	Nuclear Fuel Supply & Waste Management	16	NUCI 883, NUCI 887
NUCI 881	Light Water Reactor Fuels & Materials	16	NUCI 883
NUCI 882	Light Water Reactor Thermal-Hydraulics	16	NUCI 883
NUCI 885	Nuclear Power Conversion	16	NUCI 883
FSKN 817	Advanced Nuclear Physics	16	To be confirmed

I.4 RULES FOR THE DEGREE OF PHILOSOPHIAE DOCTOR

The Ph.D. in Engineering may follow on a Masters' in Engineering or another recognized qualification that will allow the learner to attain equivalent status and which is approved by the Post-graduate Management Committee. The study may be undertaken full time or part time.

I.4.1 INTRODUCTION

Research in the Engineering Faculty is managed by the Research Focus Areas Energy Systems and Separation Science and Technology. The research required for a Ph.D. thesis must be conducted in the sub-programmes of the Research Focus Area Unit for Energy Systems or Research Focus Area Separation Science and Technology.

Promoters take full responsibility for the training of doctoral students who are expected to work independently on a thesis.

I.4.2 ADMISSION AND REGISTRATION

The admission and registration requirements are set out in General Rules A.14.1 and A.14.2. Students are also required to have **identified a SUPERVISOR** preferably **BEFORE** applying for admission, and will not be allowed to register unless a supervisor have been confirmed.

Prospective students must first apply for **admission** to the North-West University - forms and information available from the Department of Academic Administration - Post-graduate Admissions - tel. (018) 299-4049.

After a student has been admitted, **registration** forms are issued, which must be signed by the Faculty Post-graduate Administration Manager before the student will be allowed to register. Prescribed **fees** must also be paid **BEFORE** registration.

Students must **re-register** every year according to the prescribed procedure, on or before the date set by the University.

The process can be illustrated as follows:

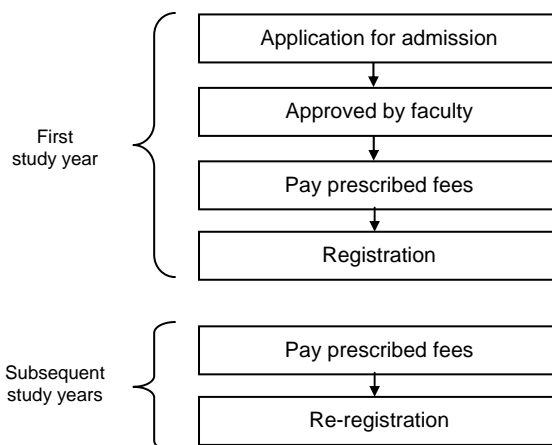

I.4.2.1 Foreign qualifications

Students holding a foreign qualification (i.e. not obtained at a South African University), are required to have the qualification evaluated by SAQA (South African Qualifications Authority) and a certificate re. the evaluation must be submitted with the application form. Visit their website at www.saqa.org.za.

I.4.3 APPROVAL OF THE STUDY PROGRAMME

Approval of the study programme is given in terms of the provisions in General Rule *A.14.4* as well as the relevant requirements in the Manual for Post-graduate Studies. **All students must consult this Manual carefully.** A version of this Manual for Post Graduate Studies is available on the university's web site (www.nwu.ac.za).

I.4.4 ADDITIONAL REQUIREMENTS

The title of the thesis, the research proposal and appointment of external examiners must be reviewed by the Post-graduate Management Committee. Further information regarding rules and procedures are contained in the general academic rules (*A.14.7*) and in the Manual for Post-graduate Study.

In addition to attaining the above-mentioned outcomes, students are also required to:

- (a) Take part in at least two formal colloquiums and/or technical conferences where aspects of their work are presented to an audience of established researchers and peers.
- (b) Have at least one full-length research paper on aspects of the dissertation submitted for publication in an accredited scientific journal before being allowed to submit the dissertation for examination.

Official **prescribed forms** are used in the post-graduate study process, and are available from the faculty post-graduate admin manager - tel. (018) 299-4020 or are available on the faculty's web site - www.nwu.ac.za.

I.4.5 ASSUMPTIONS REGARDING PRIOR LEARNING

- (a) The learner holds a Masters' degree in Engineering, or an M.Sc. in Engineering Sciences, or has been allowed to that status.
- (b) The School Director may, with notification to the faculty post-graduate management committee, allow learners who do not comply with the above-mentioned requirements to register for the M.Sc. or M.Eng. degree, on the grounds of knowledge and experience gained through prior learning. The faculty's policy with regard to Recognition of Prior Learning applies.
- (c) Programme specific assumptions are, where applicable, indicated at each programme description.

I.4.6 ARTICULATION POSSIBILITIES

With the basic and applied expertise as well as the research skills that the graduate acquires with this qualification in one of the engineering disciplines, this graduate will be empowered to, with further learning and research, pursue various other specialised fields in a variety of institutions nationally and internationally.

I.4.7 OUTCOMES

The purpose of this programme is to provide opportunity for original research by either uncovering new knowledge and/or by independent and critical analysis of existing information.

The programme outcomes will have been achieved if it is demonstrated that the candidate has made an original contribution to knowledge in a chosen field as evidenced by a thesis with proper structure, style and language that includes:

- Identification and formulation of an original research problem.
- A critical, relevant and comprehensive literature survey indicating the originality of the envisaged contribution.
- Development of the necessary research procedures and experimental facilities/numerical models.
- Execution of either an empirical or numerical investigation in order to address the research problem.
- Verification and validation of the results.
- Assessment of the results and conclusions making the case for the original contribution.

I.4.8 DURATION OF THE STUDY

The minimum term of study is two (2) years and the maximum term of study is four (4) years full-time and six years part-time calculated from the beginning of the first year of registration.

General Rule A.13.8 is applicable to learners whose Masters' registration has been converted to Ph.D. registration.

I.4.9 EXAMINATION

The examination for the Ph.D. degree is conducted in accordance with the requirements of General Rule A.14.7.

I.4.9.1 Submission of thesis for examination

According to general rule A.14.9, a thesis must be submitted for examination before or on the date determined annually by the senate and indicated in the relevant annual timetable. Certain prescribed forms are to be completed before and at submission.

Please consult the Faculty's Post-graduate Administration Manager for the necessary procedures to be followed and forms to be completed.

I.4.10**PROGRAMMES: PH.D. IN THE FACULTY OF ENGINEERING**

Please note that all students who have not yet completed the compulsory 8-credit module Research Methodology as part of their Masters' studies, has to complete this module as well before Ph.D. studies are commenced.

Programme qualification codes, curriculum codes and modules follow below. All modules are 256 credit-modules.

Branch	Programme qual. code	Curriculum code	Module code
School of Chemical & Minerals Engineering			
Chemical Engineering	703104	I901P	CEMI 971
School of Electrical, Electronic and Computer Engineering			
Computer Engineering	703113	I910P	EREI 971
Computer and Electronic Eng.	703109	I906P	REEI 971
Electrical Engineering	703105	I902P	EERI 971
Electronic Engineering	703106	I903P	EEEI 971
Electrical and Electronic Eng.	703108	I905P	ELEI 971
School of Mechanical Engineering			
Mechanical Engineering	703107	I904P	MEGI 971
Post-graduate School of Nuclear Science and Engineering			
Nuclear Engineering	703112	I909P	NUCI 971
CRCED Vaal			
Development and Management	703111	I908P	IIOB 971
All			
Engineering Science	703110	I907P	IWTS 971

Note: CRCED Pretoria offers supervision in a variety of the above study areas. Please consult the CRCED personnel at (012) 809-0653.

I.4.11

MODULE DESCRIPTIONS AND/OR OUTCOMES (ALPHABETICAL ORDER)

CEMI 875 FLUID-PHASE EQUILIBRIUM

After completion of this course, the student will be able to:

Use statistical thermodynamics theory for the determination of thermodynamic characteristics of fluids; Establish the thermodynamic equilibrium by means of molecular modelling methods; Use advanced thermodynamic theory for the development of separation processes such as membrane separation, supercritical extraction and relative distillation.

The module is presented as follows: About 40 hours contact time with the lecturer in the form of formal lectures, tutorials and discussion classes. About 120 hours of self study and preparation of assignments

CEMI 876 SEPARATION PROCESSES

After completion of this course, the student will be able to:

Select membrane processes for the separation of fluids as well as water purification; Develop and model membrane- and membrane processes for mainly fluid separation; Develop and model thermodynamically for mainly petro-chemical substances, supercritical extraction processes; Develop and model reactive distillation systems for low temperature reactions with homogenous and heterogenous catalysts.

The module is presented as follows: About 40 hours contact time with the lecturer in the form of formal lectures, tutorials and discussion classes. About 120 hours of self study and preparation of assignments

CEMI 877 COAL TECHNOLOGY I

After completion of this course, the student will be able to:

Use coal properties to determine conversion processes such as combustion, gasification and hydrogenation; Quantify the burning and gassing characteristics by means of experimental investigations; Model fluidised bed combustion and gasification for design purposes.

The module is presented as follows: About 40 hours contact time with the lecturer in the form of formal lectures, tutorials and discussion classes. About 120 hours of self study and preparation of assignments

CEMI 878 COAL TECHNOLOGY II

After completion of this course, the student will be able to:

Apply coal properties for beneficiation on coal samples from various mines; Evaluate economic aspects of coal beneficiation; Understand the most important South African coal reserves; Compare and analyse the South African context of coal production in respect of international competition; Describe, evaluate and calculate processes for various separation technologies

of international importance; Undertake research on the relevant problems of coal mining, beneficiation and stockpiling.

The module is presented as follows: About 40 hours contact time with the lecturere in the form of formal lectures, tutorials and discussion classes. About 120 hours of self study and preparation of assignments

EEII 881 DATA MINING AND KNOWLEDGE EXTRACTION

Motivation for the application of data mining and knowledge extraction, discussion of the typical application and purpose of the techniques, requirements for the process of data collection and storing, pre-processing and improvement of data integrity, exploratory searches with regard to patterns in data, distinguishing between various behavioural patterns in data, extraction of rules and/or models which present underlying behaviour, classification of behavioural patterns, cause and effect analyses, prediction of future behaviour. *Practical examples:* complex industrial processes, financial markets, logistic processes, communication networks, client behaviour as part of CRM, detection of fraud.

EEII 882 ELECTRICAL POWER QUALITY

Basis concepts, sources of harmonics and waveform distortion in a power system, effects and symptoms to utility and end-user, mathematical analysis of three-phase non-sinusoidal waveforms, penetration of harmonics in power systems, power theory, power definitions and PQ indices, computer simulations and case studies.

EEII 883 ADVANCED PROTECTION SYSTEMS

The course offers the student insight and expsure to the most important types of electrical protection systems, their design, application and behaviour. Basic fault calculations, instrument transformers, overcurrent and earth fault protection, motor, cable, transformer, overhead line and generator protection are focused on. Recent developments in SCADA and ICAP systems are also covered. Students get the opportunity during practicals to test their designs and setpoint values on real machines with a variety of relays.

EEII 884 ADVANCED SIGNAL PROCESSING

This course concentrates on digital signal processing methods. Signal processing methods can be classified into two groups namely transform orientated and other (e.g. heuristically orientated). The learner is introduced to the digitizing process and accuracy of numerical algorithms. Concepts such as vector spaces and orthogonal decomposition of signals are taught, with specific focus on the frequency (Fourrier) and time-frequency (wavelet) transforms. Image processing techniques for both the recognition of objects and image enhancement are taught. Fractals, solutions and chaos are discussed from a topological framework.

EEII 885 INFORMATION SYSTEMS FOR E-TRADE AND E-LOGISTICS

The role of e-trade and e-logistics in the modern economy, supporting role of information systems in the operation of e-trade and e-logistics, functional requirements of information systems, automated data collection, transaction processing, store of data, making data available, processing and decision support, architecture of a typical information system for e-trade and e-logistics, international technology standards for information systems, e-trade markets and requirements for successful e-collaboration, inter-dependancy between e-trade markets and logistic planning systems, support of the effectiveness of logistic operations with information systems, decision support and performance management based on business intelligence systems.

EEII 886 INFORMATION SECURITY: STRATEGIES AND TECHNIQUES

This course presents the theoretical and practical aspects of information security, from basic principles, risk analysis to management aspects. On successful completion of the course the learner will be able to:

- Identify and apply the principles of information security;
- Understand and determine information risk;
- Select appropriate technologies to secure information and understand their limitations;
- Apply information security policies; and
- Know what to do in case of a security breach.

EEII 887 KALMAN FILTERS

This course presents the theoretical aspects of random signal analysis and the minimum-mean-square-error filtering with emphasis on applications. On successful completion of the course the learner will be able to:

- Understand the concepts of Probability and Random Variables;
- Handle the Mathematical Description of Random Signals;
- Calculate the Response of Linear Systems to Random Inputs;
- Apply Wiener Filtering to Stochastic Data; and
- Develop and apply discrete Kalman Filters

EEII 888 POWER SYSTEM DYNAMICS

The course introduces students to the dynamic interaction that various power system elements have on each other during transition conditions. The dynamic interaction is described in both electrical and mechanical comparison terms. Specific attention is given to induction motors and synchronous machines and their control systems. FACTS elements that can stabilise the power system are investigated and their interaction with other power systems are studied. During practicals, students are offered the opportunity to improve the transition stability of a generator with various control systems.

EEII 889 THE COMPENSATION OF DISTORTION IN POWER SYSTEMS

Basic definitions and characteristics of power quality in power systems. Measurement of power quality phenomena. Analysis of power quality phenomena. Power quality improvement methods. Characteristics of power quality improvement equipment. Design of power quality improvement

equipment. Evaluation of power quality improvement equipment. Specification of power quality improvement equipment.

EEII 891 ADVANCED ELECTRONIC DEVELOPMENT AND DESIGN

After the completion of this module, the learner must be able to demonstrate the following specific outcomes:

- Perform an operational analysis of her / his specific system in order to define a system concept (preliminary development);
- Perform a functional analysis at preliminary design level (advanced development);
- Allocate requirements to a system or product (advanced development);
- Perform a preliminary system synthesis and evaluation;
- Draw up a development specification for her / his specific system or product;
- Draw up design guidelines and constraints (requirements) for detail design.

EEII 892 ADVANCED POWER ELECTRONICS

After completion of the module, the student should be able to:

- Demonstrate knowledge and skills pertaining to a wide range of direct current to direct current converters, and be able to design such converters.
- Have a sound knowledge of the concept of hard and soft switching of transistors.
- Have a sound knowledge of the design of high frequency magnetic components such as transformers and inductors
- Successful design and implementation of a converter.

EEII 893 ADVANCED ELECTRICAL MACHINES

After completion of the module, the student should be able to:

- Derive and apply generalised machine comparisons to induction motors and synchronised machines.
- Design, model and analyse electrical isolation systems of machines.
- Design, model and analyse the magnetic circuits of machines.
- Measure, calculate and analyse the factors influencing the performance of machines.
- Process and interpret the results of the various state monitoring techniques.

EERI 877 DIGITAL CONTROL SYSTEMS

Advanced control systems used in typical industrial environments. Aspects covered include time-discrete systems and the Z-transform, sample collection and reconstruction, multi-changing systems, open cycle and closed cycle stability, design of controller applications in multi-changing systems, condition changing formulations, minimising of cost functions, optimal controllers, realising of digital control systems, system simulation. Modern control software.

ERIE 874 NEURAL NETWORKS

Neural networks find their inspiration in the structure of the human nervous system. Artificial neural networks have a unique advantage above traditional computer programmes, in that they have the ability to learn from examples. This advantage makes neural networks suitable to solve various difficult problems. This course module focuses on different types of neural networks, the ways in which they can be trained, as well as the application of neural networks on a variety of types of problems.

Training: data analysis and visualisation, generalisation capacity, optimising, algorithms, error functions.

Topologies: memory, grouping algorithms and networks, linear networks, multi-layer perceptron networks, radial base function networks, neural networks with feedback, multi-network systems, fuzzy logic and neural networks.

Application: pattern recognition, neural networks in control systems, neural networks and regression.

ERIE 875 FUZZY LOGIC SYSTEMS

Introduction to Fuzzy systems; Description and analysis of fuzzy logic systems. Training of fuzzy logic systems using back-propagation, orthogonal least squares and nearest neighbourhood clustering is discussed. Application of Fuzzy Logic Systems in system identification is an important component of the subject.

ERIE 876 PROCESS MODELING AND IDENTIFICATION

The application of different approaches to process modeling and identification to industrial processes, such as the determination of models from basic physics, with emphasis on bond diagram techniques and fitting of model coefficients using neural networks. The successful student will be able to write computer code to do modeling from a menu with components.

FSKN 817 ADVANCED NUCLEAR PHYSICS

Fundamentals of quantum mechanics and nuclear physics for neutron cross section calculations, neutron cross section models (optical, liquid drop, etc), measurements techniques, cross section evaluation methods.

IIOB881 PROJECT MANAGEMENT

After successful completion of the module the learner will have **knowledge** and **skills** pertaining to the theory, concepts, processes, tools and techniques of project management. He/she will have applied the same to a real life study project. The learner will further have the capability and confidence to professionally manage projects in the work environment, and he/she will be proficient in the use of project management tools and techniques.

Broadly arranged in terms of the following content:

- Project management in perspective;
- Project management theory;
- Project management tools;
- Human factors in project management;
- Risk management factors in project management.

IIOB 882 MAINTENANCE MANAGEMENT

The objective of the module is to teach learners the underlying theoretical knowledge and principles of maintenance management in its broadest sense, and equip them with practical know-how of applied maintenance management in industry, thus enabling them to function effectively in this environment. After successful completion of the module the learner will have **knowledge** of the following:

- Systems Engineering (SE) Principles with emphasis on Maintainability and Reliability
- The roll of maintenance and its management in the SE “bigger picture” with special reference to plant Availability
- Reliability Engineering and general failure mechanisms
- Reliability Centred Maintenance (RCM) and its application in industry
- Maintenance theory and its application in today's high tech environment, including Maintenance Process Re-engineering
- Computerised Maintenance Management Systems (CMMS) and its application
- Maintenance Information and how to maximise its use.
- Maintenance Life Cycle Costing and the cost of maintenance
- Maintenance Management Theory at top academic level and knowledge of its application and management on plant and equipment level.

IIOB 883 CORPORATE CAREER SKILLS

The objective of this module is to enhance and accelerate the engineering graduate's effectiveness and productivity in his employment situation in general, by equipping him with relevant and essential knowledge, skills and values, as these apply to the corporate industrial sector of the economy. After successful completion of the module the learner will have **knowledge** of the following:

- The Global situation and trends that will and should influence the behaviour of the Industrial Corporate now and into the future
- The meaning and impact of the global economy
- Who the corporate stakeholders are, how they interact, and how their interests are and should be balanced. How the corporate reports to its stakeholders. How it is held accountable by its stakeholders.
- The management structure of the Industrial Corporate, with associated levels of responsibilities and built-in checks and balances
- The strategic process dictating the direction in which the Industrial Corporate develops.
- Key performance areas that drive the success of the Industrial Corporate
- Key risks that may negatively influence the corporate well-being, e.g. HIV/AIDS.
- The operational processes that supports the above (budgets, marketing & sales, the supply chain, product development, human resources, environmental & social responsibilities, financial accounting & reporting)
- The legal environment within which the corporate operates (the tax system, HR development legislation, environmental & safety legislation, etc.)
- The physical and psychological impact that the work environment places on staff. How these should be managed in order to cope effectively as an individual and employee.
- Self insight in how the learner fits into all of the above - how to optimise your contribution to your employer, while at the same time develop your career and personal well-being.

IIOB 885**ENTREPRENEURIAL CAREER SKILLS**

After successful completion of the module the student will have knowledge of:

- The various legal persons that you can choose from when launching your entrepreneurial career and their attributes.
- The roles and services offered by various funding institutions and their associated cost structures.
- Your responsibilities towards SARS, and how you should manage these.
- How to minimise your personal risks, and protect your personal assets against business risks.
- How to manage the two most important business drivers: your marketing drive and your business' cash flow.
- The business power that cyberspace offers.

After successful completion of the module the student will be able (have the skills) to do the following:

- To pick the winning opportunities and assess their risks and sustainability characteristics.
- To compile your own management accounts and financial statements and deal with other financial and taxation matters.
- To manage a business through liquidation.
- To manage yourself through sequestration - and not lose the personal assets that you built up during the good times.
- To start again - and to manage the consequences of your previous business failure.
- To identify, design, capitalise, launch and manage a business.

After the successful completion of the module the student will understand and appreciate the following values:

- You should have a broader perspective of the joys and hardships of entrepreneurial life. You should appreciate that business failure does not mean personal failure.
- You will have been coached to face a competitive, tough and unforgiving business world - and make a success of your entrepreneurial career.

IIOB 886**SYSTEM ENGINEERING**

After successful completion of the module the learner will have knowledge and skills pertaining to the theory, concepts, processes tools and techniques of systems engineering. He/she will have applied the same to a real life study project. The learner will further have the capability and confidence to use the systems engineering approach in solving problems in the work environment and he/she will be proficient in the use of systems engineering tools and techniques.

The module is broadly arranged in terms of the following content:

- Requirement formulation
- System engineering
- Software engineering
- Integrated logistic support
- Acquisition management
- System management

MEGI 874 COMPUTATIONAL FLUID DYNAMICS I

This course presents the theoretical and practical aspects of the solution of flow problems encountered in engineering science using computational fluid dynamics (CFD). On successful completion of the course the learner will be able to:

- Understand the capabilities and the limitations of CFD;
- Generate various types of computational grids;
- Derive the conservation equations for flow problems and recognise the various formulations for the conservation equations, and understand turbulence and the mechanisms which form the basis of various turbulence models;
- Understand the various discretisation techniques, formulate the finite difference discretisation of the Poisson heat equation for various boundary conditions and obtain the numerical solution;
- Perform the finite volume discretisation of a general conservation equation on an two-dimensional orthogonal grid, assemble the global coefficient matrix understanding the influence of the convective and diffusion terms, and apply the boundary values on boundary control volume;
- Understand staggered and collocated grids, velocity-pressure decoupling, and the SIMPLE (R/C/N) algorithms for the Navier-Stokes equations.
- Generate the computational grid, set up a problem and compute the solution using a commercial code.

MEGI 875 COMPUTATIONAL FLUID DYNAMICS II

This course presents the more advanced theoretical and practical aspects of the solution of flow problems encountered in engineering science using computational fluid dynamics (CFD). On successful completion of the course the learner will be able to:

- Understand the advantages and disadvantages of CFD and its industrial applications;
- Understand and apply grid transformations;
- Derive the various transient finite volume discretisations, derive the transient coupled velocity-pressure algorithms (SIMPLE and PISO) for incompressible flow on non-orthogonal unstructured grids; understand the finite volume discretisation for unstructured non-orthogonal 3D grids; understand higher-order spatial discretisation, and understand the effect of the various techniques on the convergence and accuracy of solutions;
- Understand the theory underlying unbounded solutions;
- Recognise various the types of models for two-phase flow problems, and understand the limitations of the various models;
- Understand the solution algorithms for compressible flow problems.

MEGI 876 FINITE ELEMENT METHODS

This course presents the theoretical and practical aspects of the solution of second and fourth order differential equations encountered in engineering science using the finite element method. On successful completion of the course the learner will be able to:

- Derive the weak formulation and obtain the Galerkin finite element formulation for one- and two-dimensional problems;
- Discretise the computational domain, compute the contributions from the elements to assemble the global equations, apply the boundary conditions, solve the equations and post-process the results;

- Extend the method to solve systems of differential equations, non-linear problems and problems with various constraints.

MEGI 877 FINITE ELEMENT METHODS FOR FLOW

This course presents the theoretical and practical aspects of the solution of the Navier-Stokes equations using the finite element method. On successful completion of the course the learner will be able to:

- Derive the weak formulation and obtain the Galerkin finite element formulation for the Navier-Stokes equations in one and two dimensions;
- Distinguish between and implement the fully coupled classical velocity-pressure and the penalty function approaches, and employ Petrov-Galerkin upwinding.
- Distinguish between and implement the segregated SIMPLE, SIMPLER and SIMPLEST algorithms;
- Extend the method to include non-isothermal flow problems.

MEGI 878 ENERGY MANAGEMENT

Introduction to energy management, overview of energy audit process, energy accounts, economic analysis and life-cycle costs, lighting, refrigeration and air-conditioning, combustion processes and use of industrial waste, steam generation and distribution, control systems, maintenance, insulation, process energy management, alternative energy sources, water management.

MEGI 879 ADVANCED ENGINEERING THERMODYNAMICS

Exergy and its use in open and closed systems. Exergy analysis of simple and complex systems. The time value of money. Use of exergy in Thermo-Economic analysis.

MEGI 884 ADVANCED STRENGTH OF MATERIALS

Linear tension and distortion: Tension transformations, Mohr circle for tension and distortion, tension-distortion of isotropical and orthotropical materials.

Non-elastic material behaviour: Tension distortion behaviour (elastic and plastic), application of load-deflection relationships, failing criteria and safety aspects.

Non-symmetric bending of straight flanges: Maximum tensions, deflections and orientation of the neutral axis under non-symmetrical burden, complete plastic burden under non-symmetrical bend.

Tension concentrations: Neuber nomogram, theoretical tension concentration factors (Shigley), sensitivity.

Fatigue: Design according to Goodman, Gerber and DE elliptical criteria.

Contact Tensions: Analysis of point and line contact tensions.

MGII 885 THERMAL-FLUID SYSTEMS MODELLING

After completion of this course the student must be able to:

- Integrate fundamental knowledge of thermodynamics, fluid mechanics and heat transfer with specialised techniques required to simulate thermal-fluid systems for both steady state and transient conditions.

- Apply higher level engineering synthesis skills and specialised software tools to create mathematical models with the appropriate degree of complexity that can be used in the simulation and design of thermal-fluid components and systems.

MGII 887 GAS TURBINE THEORY AND PERFORMANCE

Axial Compressors: Fundamental concepts regarding axial compressors, general axial flow compressor design, axial compressor stage design principles, velocity triangles, thermodynamic design principles, off-design performance, surge and stall, blade design, mechanical integrity.

Axial turbines: Fundamental concepts of axial flow turbines, thermodynamics of gas turbine process, turbine velocity triangles, turbine blade design.

Combined gas turbine cycle: Combining of compressor and turbine into a gas turbine cycle, compressor/turbine matching, simulation of gas turbine cycle, transient gas turbine cycle simulations.

MEGI 889 MATERIALS SELECTION FOR DESIGN

The design process, engineering and their properties, performance and selection indices, materials selection charts, material selection and selection strategies, materials selection – case studies, selection of material and shape, shape – case studies, multiple constraints and compound objectives, case studies: multiple constraints and compound objectives, materials processing and design, case studies: process selection, modern data sources, case-studies: use of data sources; ferrous alloys, non-ferrous alloys, polymers, ceramics composites, materials, aesthetics and industrial design.

MEGI 894 COMPOSITE MATERIALS

Properties of composite materials: polymer matrix materials

Elastic properties of fibre reinforced composite materials: micromechanical models, laminate analysis, short fibre composites.

Strength of composite materials: Tensile strength, fibre orientation and tensile properties, tensile properties of multilayered laminates, compressive strength, shear strength, toughness and fatigue life.

MEGN871 PRESSURIZED WATER REACTOR TECHNOLOGY

Light water reactor core physics; Design of fuel elements and core: design bases for Koeberg NPP core design; Components of reactor: design bases for reactor pressure vessel reactor internals, control rods; Components of Primary system: design bases for MCP, PRZR (PORV and safety valves) SG, MSIV, GCT to ATM etc.; Design bases transient and accident analysis: SAR requirements, ECCS acceptance criteria, design conditions of the PWR plants; Regulatory framework (NNR, NRC, IAEA): Codes, standards, specifications.

NUCI 511 NUCLEAR ENGINEERING I

On the completion of this module you should have reached the partial level required to enter the M-programme in nuclear engineering. You should be able to reveal and apply basic knowledge in atomic and nuclear physics in nuclear engineering fields, obtain knowledge of; how radiation interacts with matter,

about various nuclear power reactors and the fuel cycles, neutron slowing down and diffusion in nuclear reactors with introductory knowledge of reactor analysis and time dependent behaviour of nuclear reactors, thermal hydraulics of nuclear reactors, radiation protection, radiation shielding, licensing, safety and environmental aspects of nuclear power.

With the knowledge you have obtained from this model you will be able to solve some basic problems related to nuclear energy, communicate with the public about the benefits and problems of nuclear power.

This module will give you a better understanding of the neutronics analysis modules that will be offered in the M-programme in nuclear engineering.

NUCI 621 THERMAL-FLUID SCIENCES

On the completion of this module you should be able to:

- Demonstrate a thorough understanding of Thermodynamics, Fluid Mechanics, Heat transfer and Turbo machines by analysing and solving simple and complex industry related problems.
- Demonstrate an understanding of how the different constituent parts of an integrated system interact and influence each other by describing the interaction and calculating the effect of changing certain variables
- Evaluate the performance of simple and complex systems and propose actions to improve their performance.

NUCI 671 MATHEMATICS FOR NUCLEAR ENGINEERS

On the completion of this module you should be able to solve mathematical problems related to Nuclear Engineering. With this knowledge you should be able to:

- Use different methods to solve partial and differential equations analytically.
- Solve partial and differential equations numerically.
- Use this basic knowledge to solve more complex problems.
- Use the methods learnt here in other nuclear engineering courses.

NUCI 874 ADVANCED REACTOR ANALYSIS I

- On the completion of this module, learners will be able to demonstrate the minimum basic knowledge for Nuclear Reactor Analysis essential in neutronics.
- Sufficient knowledge of nuclear parameters necessary for reactor neutronics calculations acquired for diffusion and slowing down theories and other calculation methods in calculating the neutron flux distribution within a reactor.
- An advanced knowledge of reactor analysis and be able to solve advanced problems in this regard.

NUCI 875 ADVANCED REACTOR ANALYSIS II

On the completion of this module you will have obtained a basic knowledge in some advanced methods of reactor analysis. With this knowledge you should be able to:

- Understand the state-of-the-art calculational methods of reactor analysis and their implementation in computer codes.
- You should be able to run and interpret the results of such computer codes as a member of a nuclear design team.
- You should furthermore be able to take part in research for development of new calculational methods.
- You should assume the role of a neutronics specialist and take part in joint projects with thermal-hydraulics specialists.

Use the knowledge you've obtained as a base for pursuing doctoral level research in neutronics. Since some methods covered in the course have applications in other areas of engineering you could use your knowledge also there.

NUCI 876 HIGH TEMPERATURE GAS-COOLED REACTOR THERMAL-FLUID ANALYSIS

Upon completion of this module, learners will possess a comprehensive and systematic knowledge base and skills in the following:

- Physical properties of fluids and solid materials used in HTRs;
- Pressure drop relationships for flow through a pebble bed reactor;
- Heat generation in HTRs;
- Heat transfer mechanisms in pebble bed HTRs;
- Conservation equations governing heat transfer and fluid flow in HTRs;
- Numerical solution techniques of the governing equations; and
- HTR design bases.

Learners will also be able to independently perform simulations of all the design baselines for HTRs using existing codes and interpret the results.

NUCI 877 HIGH TEMPERATURE REACTOR FUELS AND MATERIALS

The learners are expected to have the following qualifications upon the completion of this course;

- Understand the reasoning for selecting proper materials for HTR's
- Demonstrate knowledge of basic steps of design and fabrication of high temperature reactor fuel
- Calculate main operational parameters such as fuel temperature, burnup, CO production etc.
- Discuss main problems and ways of improvements for HTR fuel and structural materials.
- Relate reactor physics, thermal hydraulics, and reactor design aspects with reactor fuel and materials

NUCI 878 HIGH TEMPERATURE REACTOR TECHNOLOGY

Principal aspects of HTR and applications, core physics, design and lay-out of fuel elements and core, thermo-hydraulic of core, reactor components, primary system components, safety and licensing, accidents analysis, operational aspects, coolant and materials (tribology of helium), intermediate and final storage, cost aspects, development of HTR. On the completion of this module,

you will have obtained a basic knowledge in the field of HTR technology, safety aspects and applications of HTR.

NUCI 879 NUCLEAR PROJECT MANAGEMENT

The module focuses on the project lifecycle phases and processes, and nine knowledge areas.

Knowledge Areas

- Scope
- Time
- Cost
- Quality
- Human Resources
- Communication
- Risk
- Procurement
- Integration

Phase and Processes

- Initiation
- Planning
- Executing
- Controlling
- Closing

NUCI883 NUCLEAR ENGINEERING

On the completion of this module, you will have obtained the basic knowledge in understanding how nuclear power plants are designed and operated. With the knowledge, you have obtained from the module you will be able to solve basic thermal-hydraulic problems related to nuclear reactor engineering and communicate with the engineering community about these problems. Your knowledge in the thermal-hydraulic analysis of nuclear reactors as well as knowledge of nuclear fuel and reactor operations will enable you to work in the nuclear industry.

NUCI 886 PEBBLE BED REACTOR DESIGN

Physical processes in a reactor, modelling / computational representation of individual events in reactor operation, the interaction of individual events, simulation of fuel cycles, reactor life and accident simulation, design project.

NUCI 887 REACTOR ANALYSIS

On the completion of this module, learner will obtain the minimum basic knowledge of Nuclear Reactor Analysis that is essential for all nuclear engineers. Sufficient knowledge of nuclear parameters that are necessary for reactor neutronics calculations will be acquired so that the simplified diffusion and slowing down theories can be used in calculating the neutron flux distribution within a reactor. Learner completing this module will have the basic knowledge of reactor dynamics.

NUCI 888 REACTOR SAFETY

On the completion of this module you will have obtained a basic knowledge in the field of reactor safety. With this knowledge you should be able to:

- Understand accidental situations and you should have learned the necessary methods to evaluate them.
- You should be able to communicate with the engineering community about these problems.
- You should furthermore be able to carry out estimations for important accidents in nuclear plants.
- Use the basic knowledge to go deeper and to use complex programmes for safety analysis should be available.
- Use the knowledge to work in the nuclear industry or in safety organisations for supervision of nuclear power plants.

NVMI 874 RESEARCH METHODOLOGY

The main outcomes are the following:

1. Understanding the basic research process; and
2. Being able to implement the process.

Other detail outcomes include the following:

- Knowing how to adopt a structured approach towards research
- Knowing how to perform an effective literature study
- Performing a literature survey, for your proposal, and for the literature survey deliverable
- Being able to write your own research proposal
- Writing a research proposal as deliverable
- Learning proper writing skills and the different elements of a dissertation or thesis
- Learning the principals of plagiarism
- Applying these principals in the plagiarism work
- Learning from the mistakes that have been made by other researchers
- Giving you a head start to completing your Masters' or PhD